

OCEAN AVENUE STAIRSCAPE

PUBLIC ART PROPOSAL FOR UNITY PLAZA, SAN FRANCISCO

BY THE ARTIST TEAM OF WOWHAUS

MAY, 2015

OCEAN AVENUE STAIRSCAPE

Rendered in highly durable ceramic enamel, a striking tableau of historic photographs from the OMI (Oceanside, Merced, Ingleside) neighborhood will cascade down the connector staircase at Unity Plaza, creating an engaging interactive public art experience.

Each 6" h ceramic enamel riser contains a "slice" of the overall composition, which is comprised of large-scale images of historical or cultural significance, along with a "frieze" of smaller images at the top tread of each set of stairs. The images shift and change as the viewers approaches the staircase. Scale shifts encourage interaction, with the larger images visible from a distance and smaller images providing additional information when examined up close.

Significant community engagement informed the artwork, with community members providing input regarding the cultural and architectural history of the neighborhood as well as contributing photographs that are incorporated into the piece. A "key" sign installed near the staircase — also rendered in ceramic enamel - will provide detailed information about key photos; photo credits and information about all the images in the artwork will be provided on a community web site, "Outsidelands.org". This information will also be available in print form at the local Ingleside library. The ceramic enamel panels will be integrated into the newly constructed stairs via a secure installation system designed in collaboration with the City's landscape design team, Jasmine Kaw and Lawrence Cuevas.

ARTWORK



KEY

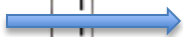

NOTES

1. SEE SHEET L-3.2 FOR MATERIALS AND FINISHES
2. EXACT LOCATIONS OF ALL FINISHES TO BE TOLD APPROVED BY ARCHITECT

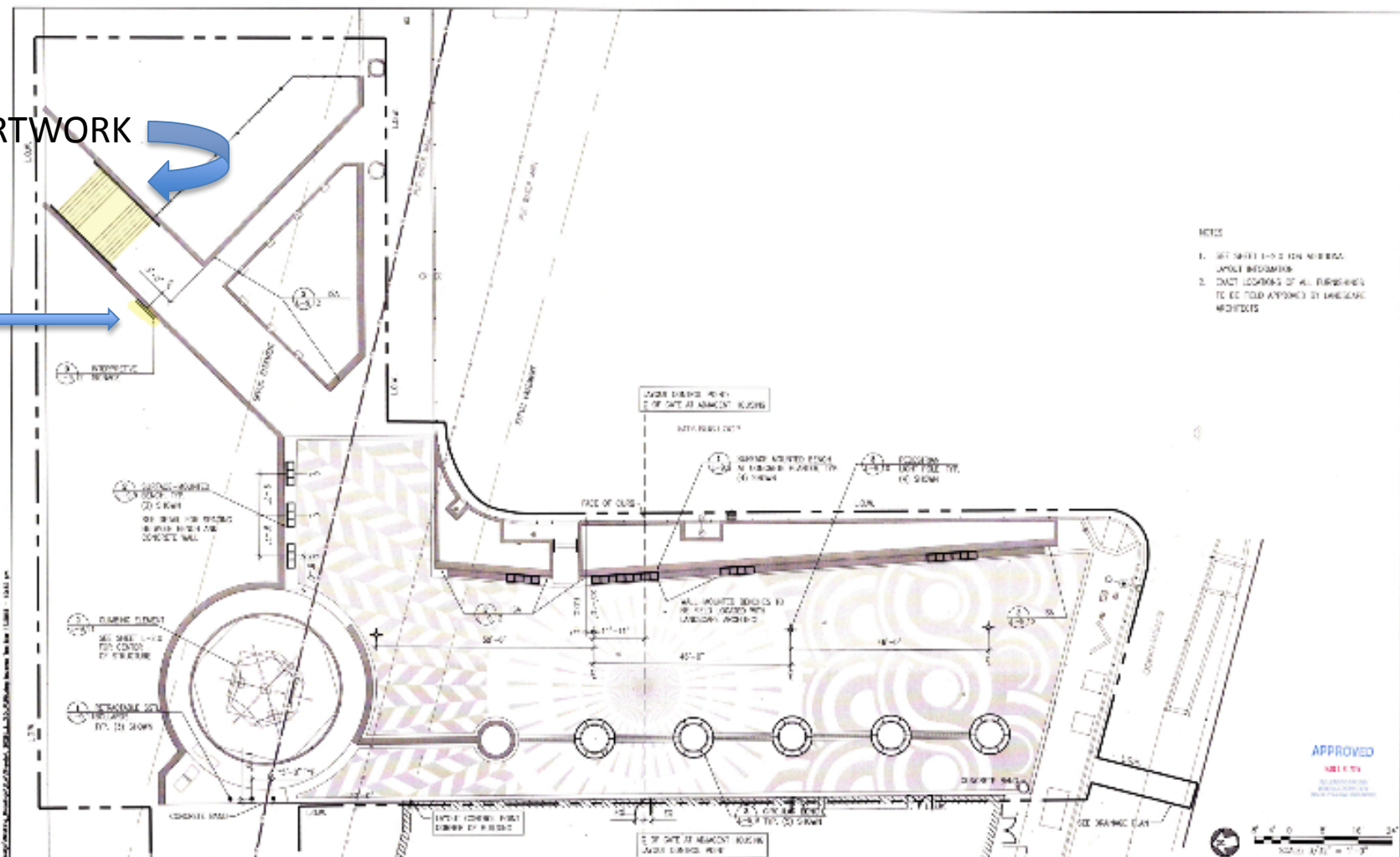

APPROVED
 [Signature]
 ARCHITECT



NO.	REV.	DATE	BY



**BUILDING DESIGN
 AND CONSTRUCTION DIVISION**
 DEPARTMENT OF PUBLIC WORKS
 CITY AND COUNTY OF SAN FRANCISCO



DESIGNED BY	DATE	APPROVED BY	DATE
DRAWN BY			

UNITY PLAZA DEVELOPMENT PROJECT		PROJECT NO. 1330
FURNISHINGS PLAN		WORK NO. L-3.0
		DATE OF WORK 1.07.11

CONCRETE STEPS, TYP.
N.T.S.

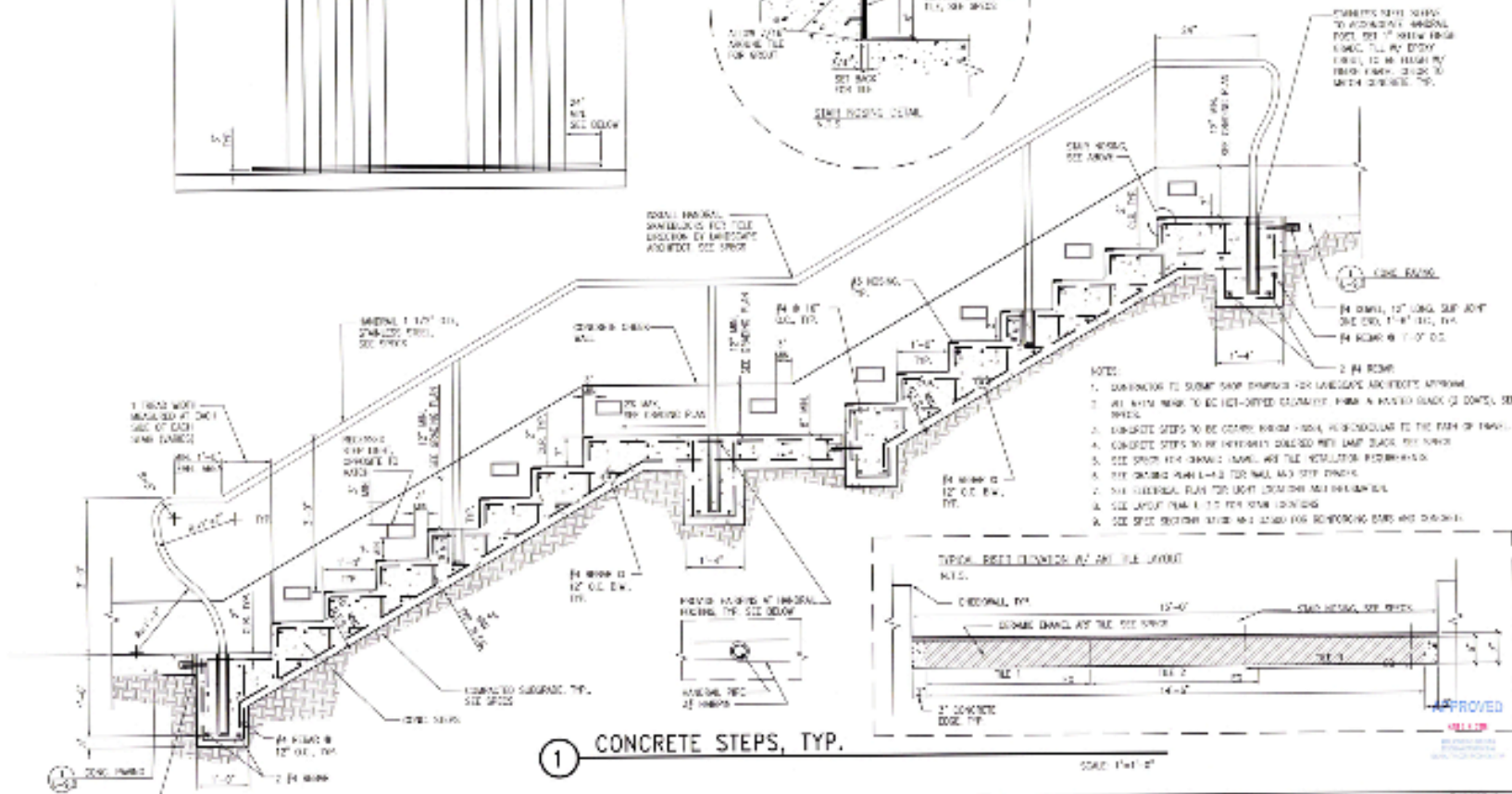
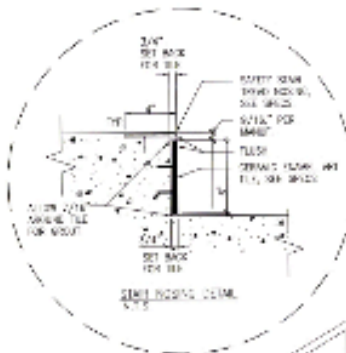
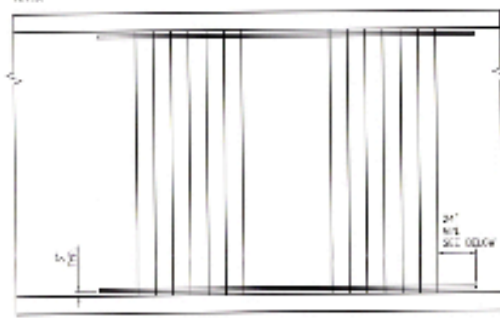

- NOTES:
1. CONNECTION TO SLUMP SHAP CHANGES FOR LANDSCAPE ARCHITECT'S APPROVAL.
 2. ALL STEPS NEAR TO BE SET-DRIED CLEANLY FROM A MIN. TO GRADE (2 CONCS. SEE NOTES).
 3. FINISHED STEPS TO BE COMPLY FINISH - SHALL BE PERPENDICULAR TO THE FACE OF TREADS.
 4. CONCRETE STEPS TO BE FINISHED POLISHED PER LAST PAGE SET NOTES.
 5. SEE SPEC FOR FINISH: SHALL USE TILE INSTALLATION PER SPEC'S.
 6. SEE GENERAL PLAN FOR LIGHT CRACKING AND REPAIRS.
 7. SEE GENERAL PLAN FOR LIGHT CRACKING AND REPAIRS.
 8. SEE SPEC SECTION 05100 FOR REINFORCING BARS AND CHAINS.

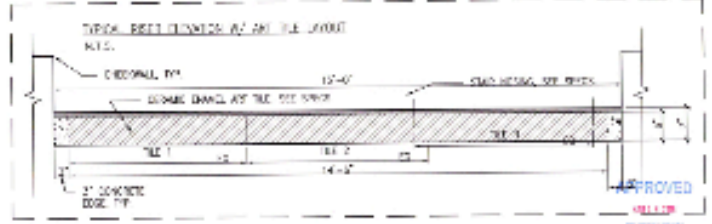

1 CONCRETE STEPS, TYP.

SCALE: 1/4\"/>

NO.	DESCRIPTION	DATE
1	ISSUED FOR REVIEW	11/11/14
2	FOR PERMITS	11/11/14
3	FOR CONSTRUCTION	11/11/14



BUILDING DESIGN AND CONSTRUCTION DIVISION
DEPARTMENT OF PUBLIC WORKS
CITY AND COUNTY OF SAN FRANCISCO



DESIGNED BY	DATE
DRAWN BY	DATE
CHECKED BY	DATE
APPROVED BY	DATE

APPROVED BY	DATE
REVISIONS	DATE

UNITY PLAZA DEVELOPMENT PROJECT

CONSTRUCTION DETAILS

PROJECT NO.	1504
DRAWING NO.	L-9.8
DATE OF ISSUE	11/11/14

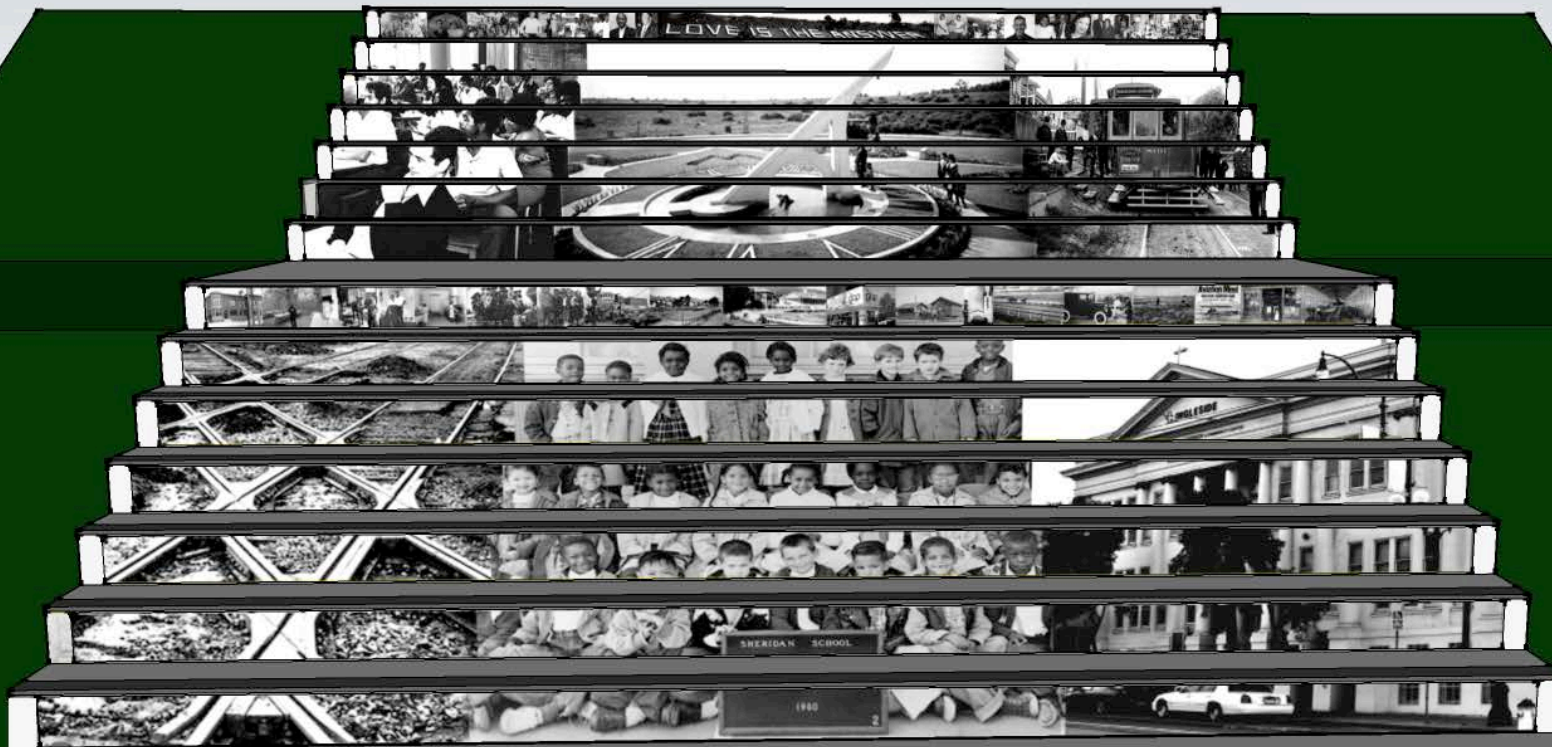

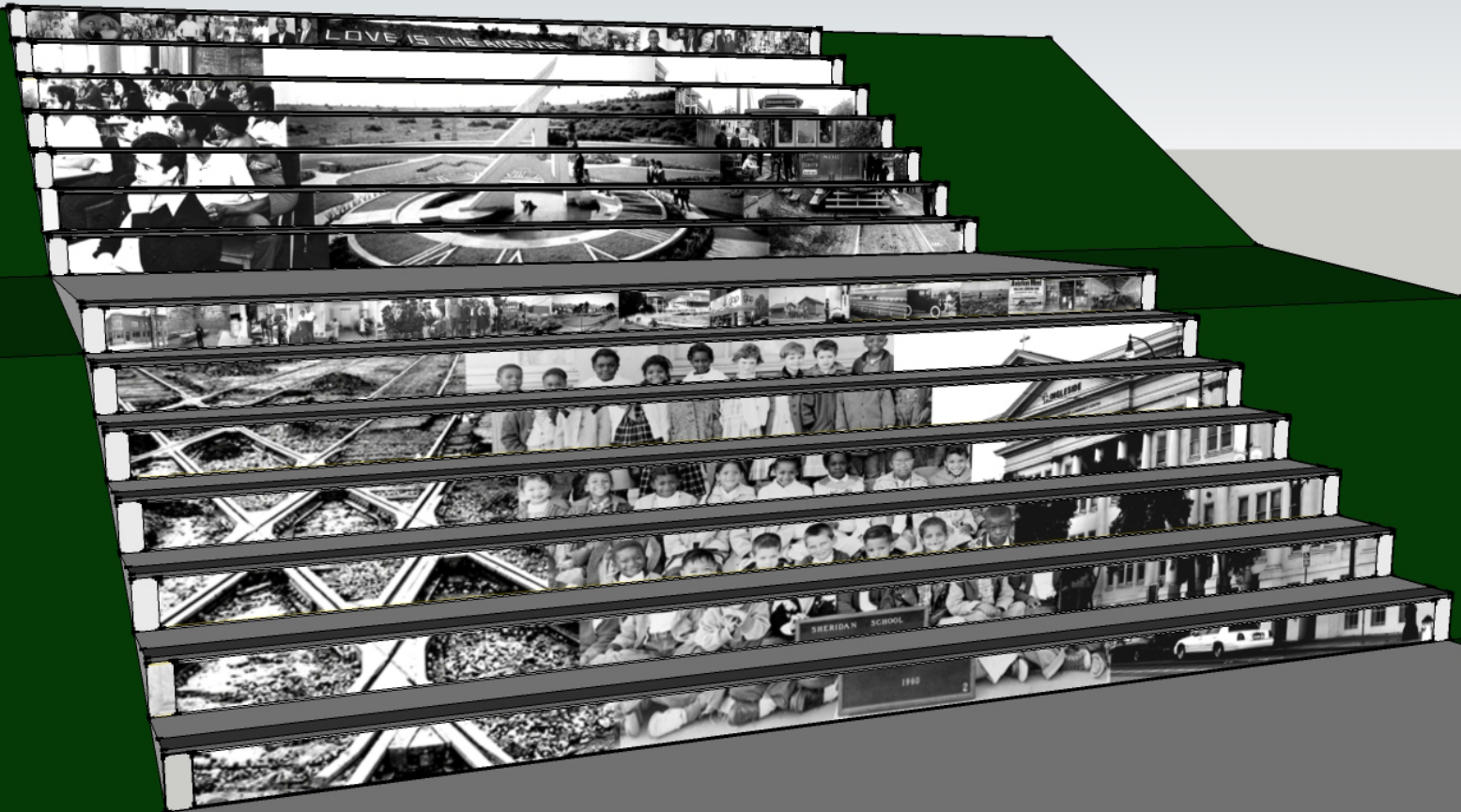

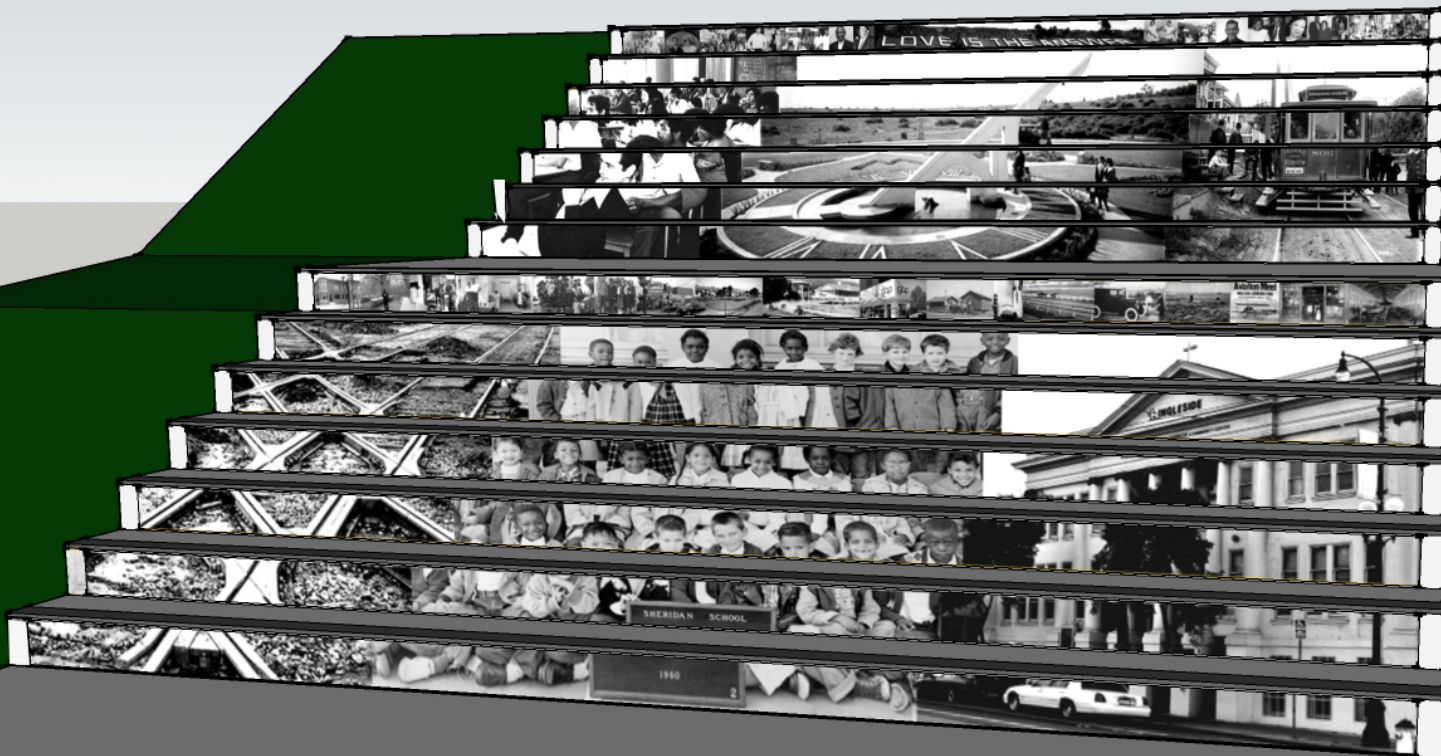

LOVE IS THE MESSAGE

SHERIDAN SCHOOL

1960

CLIMBES

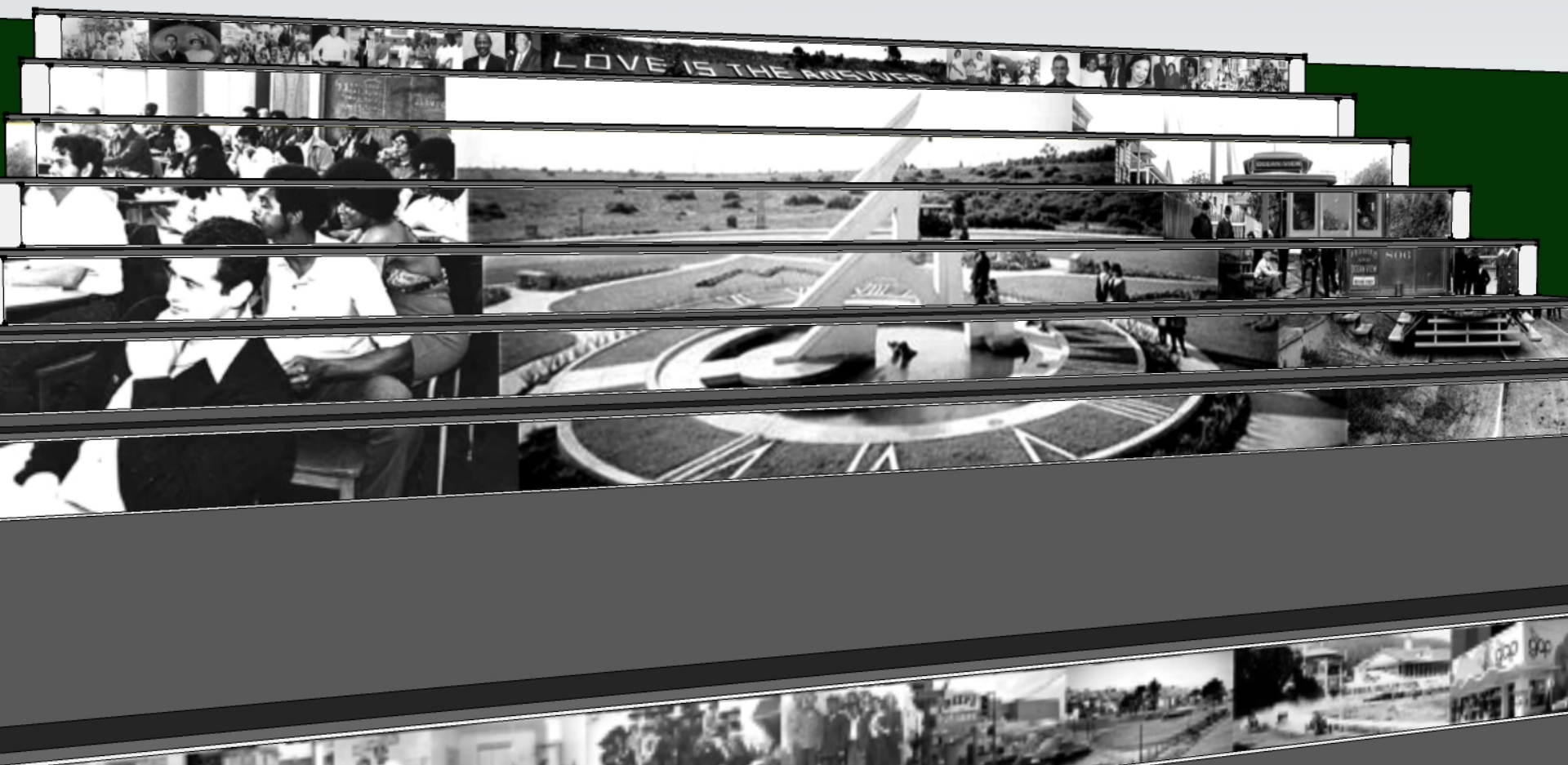

MULTIPLE PHOTOS IN PHOTO "FRIEZE" IN TOP RISER OF EACH SET OF STAIRS

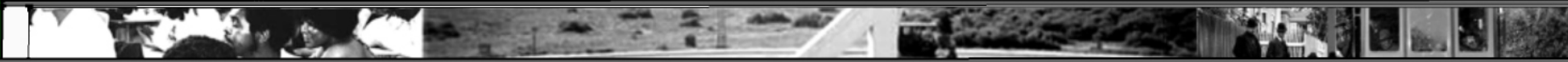

SAMPLES OF HISTORIC PHOTOS INCLUDED IN PHOTO "FRIEZES"



Orphanage



Ingleside Race Track



Picking wild flowers at Ingleside. San Francisco, California





'08 Earthquake Shelter in Ingleside Track Horse Barn



CERAMIC ENAMEL DETAIL



PLAN VIEW scale: 1 1/2" = 1'

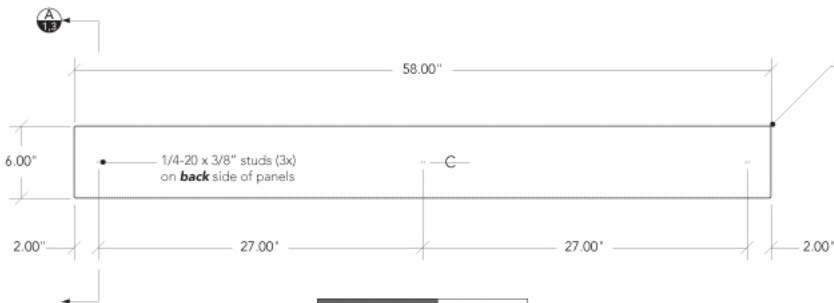

ELEVATION VIEW scale: 1 1/2" = 1'

corners welded and ground smooth to match break radius



SIDE VIEW scale: 1 1/2" = 1'

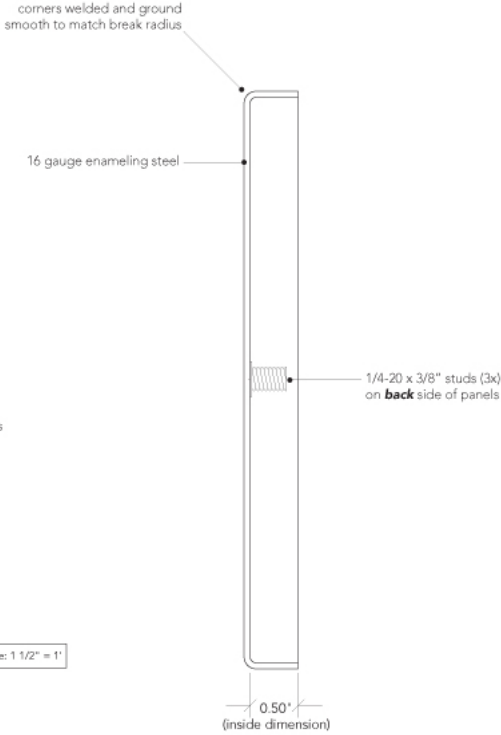

SECTION VIEW scale: 1 : 1

project	description	drawn by	project manager	date	seen	quantity	scale	revision	page no.
8950 Unity Plaza Stairs	58" x 6" x 1/2" (I.D.) panels 3x 1/4-20 x 3/8" studs on back side of panels 16 gauge enameling steel	SV	Steve Vandyk	10/29/14	A	42 (forty two)	as shown		1 of 3

- Preliminary Design
- Design Development
- Final Design



1825 Empire Industrial Ct. Suite A
Santa Rosa, CA 95403

T 707 573 6868
F 707 573 6888
kvoindustries.com

CERAMIC ENAMEL DETAIL



PLAN VIEW scale: 1" = 1'

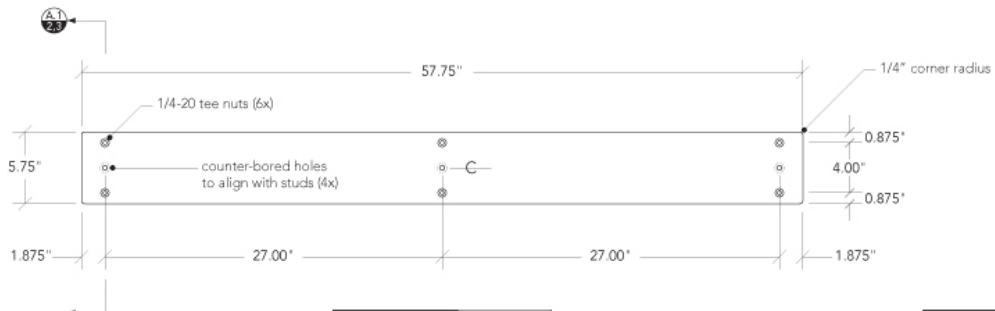

ELEVATION VIEW scale: 1" = 1'



SIDE VIEW scale: 1" = 1'

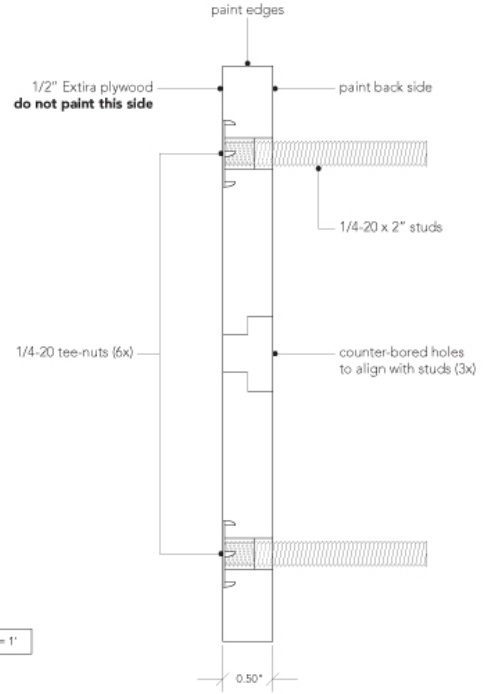

SECTION VIEW scale: 1" = 1'

project	description	drawn by	project manager	date	item	quantity	scale	revision	page no.
8950 Unity Plaza Stairs	57.75" x 5.75" x 1/2" wood backers 6@ 1/4-20 tee nuts 3@ counter-bored holes 1/2" Extra plywood painted finish (black)	SV	Steve Vandyk	10/29/14	A.1	42 (forty two)	as shown		2 of 3

- Preliminary Design
- Design Development
- Final Design



1825 Empire Industrial Ct. Suite A
Santa Rosa, CA 95403
T 707 573 6868
F 707 573 6888
kvoindustries.com

CERAMIC ENAMEL DETAIL

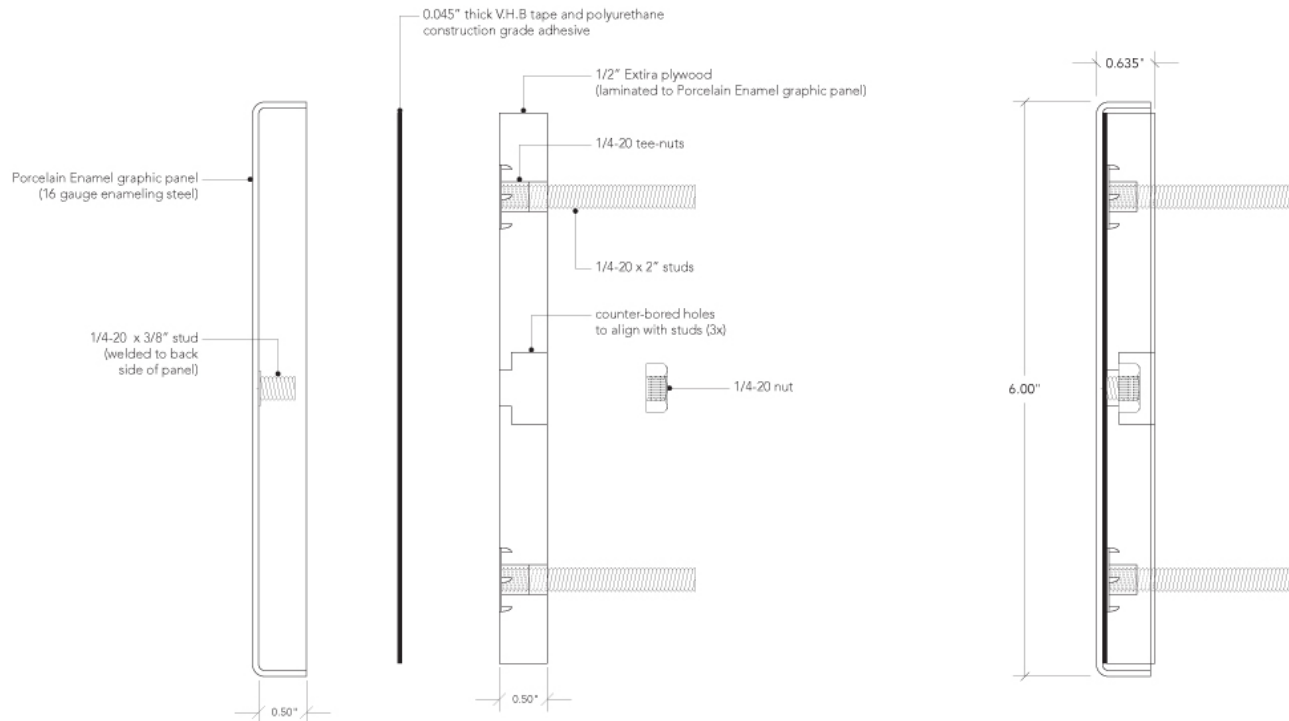

SECTION VIEW scale: 1 : 1

project	description	drawn by	project manager	date	item	quantity	scale	revision	page no.
8950 Unity Plaza Stairs	section view	SV	Steve Vandyk	10/29/14			as shown		3 of 3

- Preliminary Design
- Design Development
- Final Design



1825 Empire Industrial Ct. Suite A
Santa Rosa, CA 95403

T 707 573 6868
F 707 573 6888
kvoindustries.com

OCEAN AVENUE STAIRSCAPE

HOMEWOOD TERRACE ORPHANAGE
1921- Late 1960's
Faxon Ave & Keystone Way

LOCAL YOUTH, 2000
Worked with Rev. Roland Gordon to revitalize Phelan Loop

LEONARD "LEFTY" GORDON
Community Leader
1939-2000

LEFTY GORDON MEMORIAL GARDEN
2000, at Phelan Loop

SUNDIAL, 1912
Ingleside Terraces
After '06 quake, Ingleside's population grew tenfold

DIVERSITY
OMI is historically one of the city's most diverse neighborhoods

CITY COLLEGE, 1973
(Est. 1935)
Ocean Avenue Campus
is the college's primary campus

EL REY THEATER, 1930's
1970 Ocean Avenue

PHELAN LOOP
1960's

INGLESIDE RACETRACK
1895-1906 • Cars, horses & bicycles raced here

EARTHQUAKE REFUGEES, 1906
Ingleside Racetrack stalls served as temporary housing after '06 quake

RAIL & STREETCAR INTERSECTION
1904
San Jose Ave. & Sagamore Ave.

INGLESIDE PRESBYTERIAN CHURCH
Founded 1906
1345 Ocean Avenue
Church built 1921

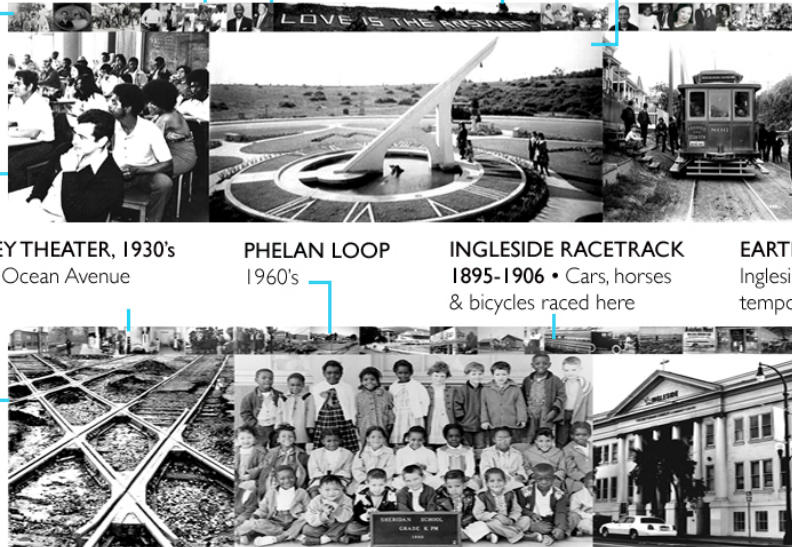

UNITY PLAZA STAIRS ARTWORK BY WOWHAUS (SCOTT CONSTABLE & ENE OSTERAAS-CONSTABLE) © SAN FRANCISCO ARTS COMMISSION, 2016
WWW.OUTSIDELANDS.ORG FOR MORE INFORMATION OR VISIT THE INGLESIDE LIBRARY, 1298 OCEAN AVENUE, SAN FRANCISCO

KEY TO ARTWORK: 6' long x 3.5' high ceramic enamel sign adjacent to staircase

SLIMLINE

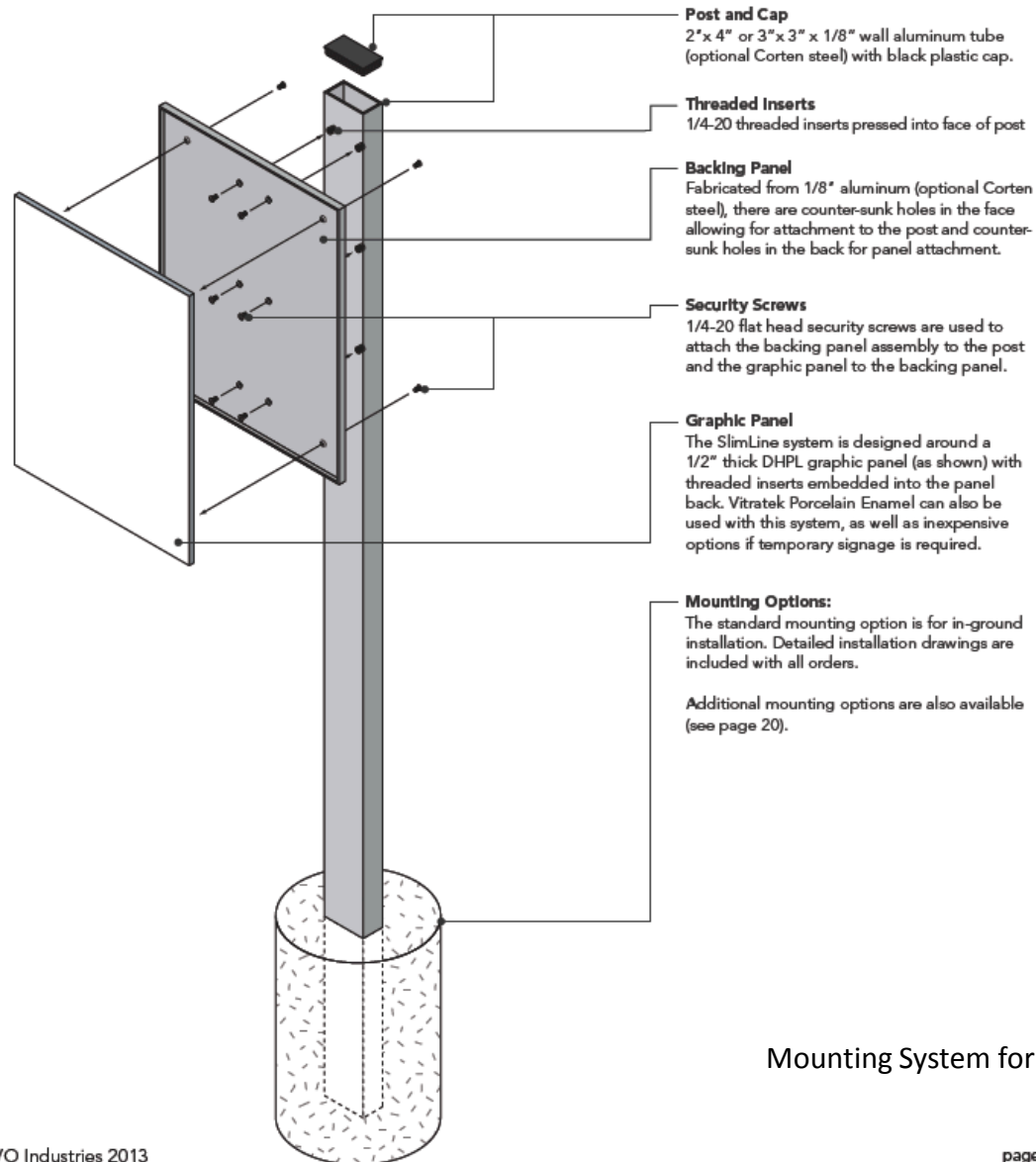

Mounting System for Key Signage

Western Neighborhoods Project



Preserving the history of San Francisco's West side

Articles | Events | Photos | Video | Neighborhoods | Map | Message Boards | Shop |

Upcoming Events

Bay Area Heritage Open House
May 7, 2015 5:00pm-8:00pm (Thursday) at Mechanics Institute
Join WNP's Woody LaBounty and David Gallagher at the Mechanics' Institute on May 7th to meet representatives from other local cultural, historical and genealogical entities at this Open House More Info...

WNP Event
Bike tour of Western Golden Gate Park
Jun 6, 2015 10:00am-12:30pm (Saturday)
WNP Members! Join us for a bike tour of western Golden Gate Park featuring the history and design of the wilder part of San Francisco's most iconic park More Info...

[More Events...](#)

Featured



"Highlights of the Private Collector Images"

New this Month

[Recent](#) | [Random](#) | [Richmond Articles](#) | [Sunset Articles](#)

Podcast Episode 119: Golf Courses
San Francisco's earliest golf courses were created on the city's west side, including the Ingleside.

Podcast Episode 118: The 1906 Earthquake and Fire
A seminal day for San Francisco and the western neighborhoods: April 18, 1906

Podcast Episode 117: Olympic Grounds
Guest Angus Macfarlane tells us when San Francisco's Olympic Club cavorted in the heart of the Inner Sunset District.

Streetwise: Making a Splash
San Francisco swimming pools, past and present

Podcast Episode 116: Courtesy of a Private Collector
Nicole Meldahl describes the significance and breadth of the "Courtesy of a Private Collector" historical images and how WNP is conserving, cataloging, and sharing them.



Core Partner - PPIE100

Now On Sale



Sutro's Glass Palace

Podcast

Western Neighborhoods Project

Latest Photos



Camp Cheerful

Golden Gate Park Refugees

Earthquake Refugees

Big Rec Refugees

Information & photo credits for each photo in the artwork to be included on this local community website. URL & scan code to be included on Key Signage. Print version also available at Ingleside Library.