



MILLER COMPANY  
landscape architects

1585 FOLSOM ST. SAN FRANCISCO, CA 94103  
415.252.7288 www.millercomp.com

**RINGOLD HISTORY  
WALK  
SAN FRANCISCO, CA**



NO.	DATE	REVISIONS
1	9/30/15	ARTS COMMISSION

PROJECT NO. 1314  
DATE SEPT. 30, 2015  
SCALE AS SHOWN

DRAWING TITLE  
**VIGNETTE**

SHEET NO.  
**L0.0**

**1 RINGOLD ALLEY @ 8TH STREET - PROPOSED CONCEPT**

All ideas, design arrangements and plans indicated or represented by this drawing are owned by, and are the property of Miller Company Landscape Architects and were created, evolved, and developed for use on and in connection with this project. None of such ideas, arrangements, or plans shall be used by or disclosed to any person, firm, or corporation for any purpose whatsoever without the written permission of Miller Company Landscape Architects. Filing of these drawings or specifications with any public agency is not a publication of the same. No reproduction is herefore permissible without the written consent of Miller Company Landscape Architects.



**1** RINGOLD ALLEY @ 8TH STREET - SE CORNER  
SITE OF NEW PARK & PROPOSED FEATURE CROSSWALK



**2** RINGOLD ALLEY @ 8TH STREET - NE CORNER  
PROPOSED SITE OF BULB-OUT CHICANE WITH BRONZE BOOT PRINTS, FEATURE PAVEMENT & STANDING STONES



**3** RINGOLD ALLEY @ NEW BUILDING ENTRY  
PROPOSED SITE OF BULB-OUT CHICANE WITH FEATURE PAVEMENT, BRONZE BOOT PRINTS & STANDING STONES

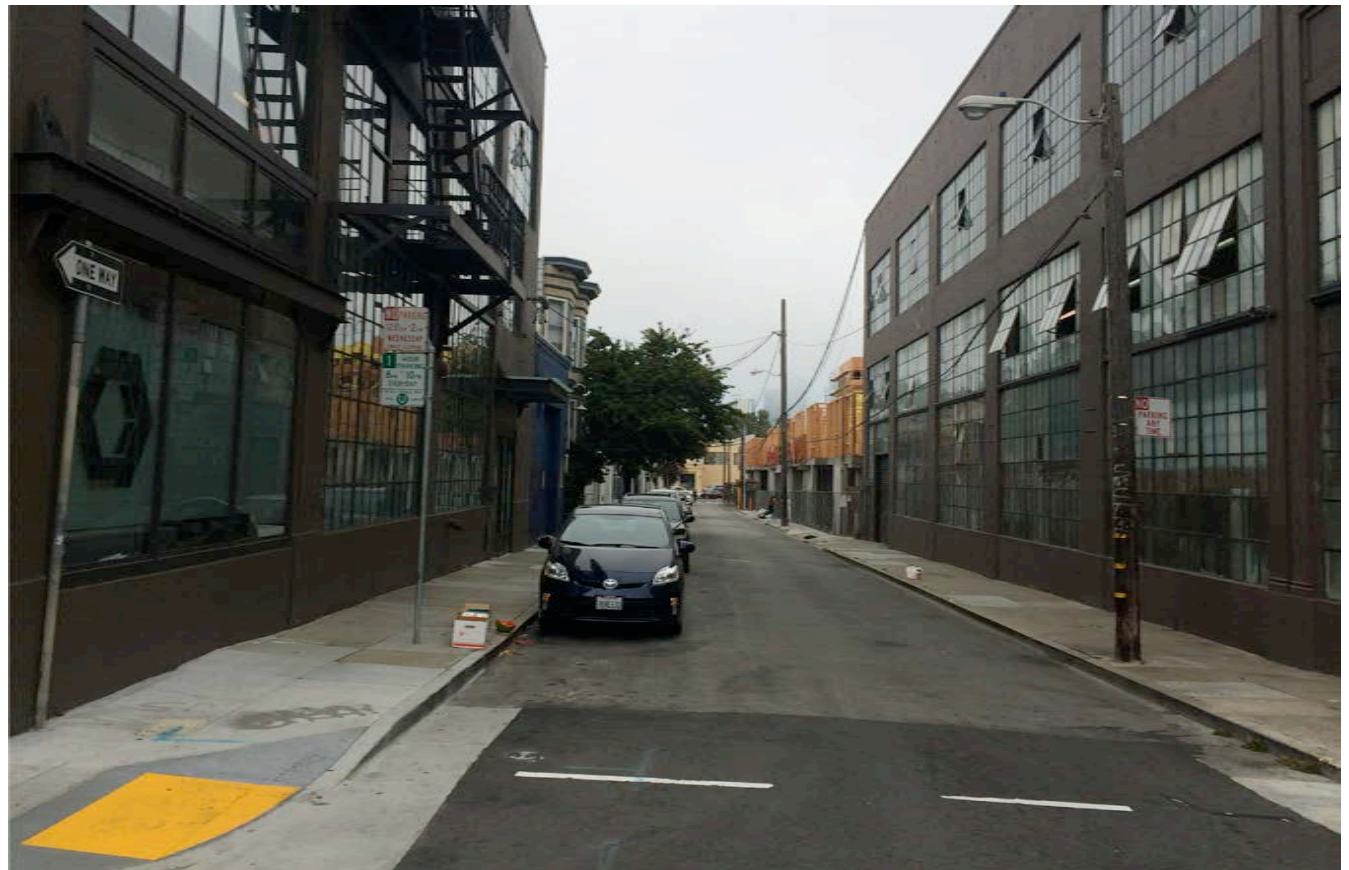

**4** RINGOLD ALLEY @ 9TH STREET  
PROPOSED SITE OF RAISED CROSSWALK WITH FEATURE PAVEMENT & BULB-OUT CHICANE WITH HISTORIC MARKER

RINGOLD HISTORY  
WALK  
SAN FRANCISCO, CA



NO.	DATE	REVISIONS
1	9/30/15	ARTS COMMISSION

PROJECT NO. 1314  
DATE SEPT. 30, 2015  
SCALE AS SHOWN

DRAWING TITLE

EXISTING CONDITIONS

SHEET NO.

**L0.1**



RAISED CROSSWALK WITH FEATURE PAVEMENT  
(LOCAL PRECEDENT SHOWN)



CHUCK ARNETT'S MURAL FROM TOOL BOX



ETCHED GRANITE HISTORIC INFORMATION MARKER  
(PRECEDENT IMAGE)

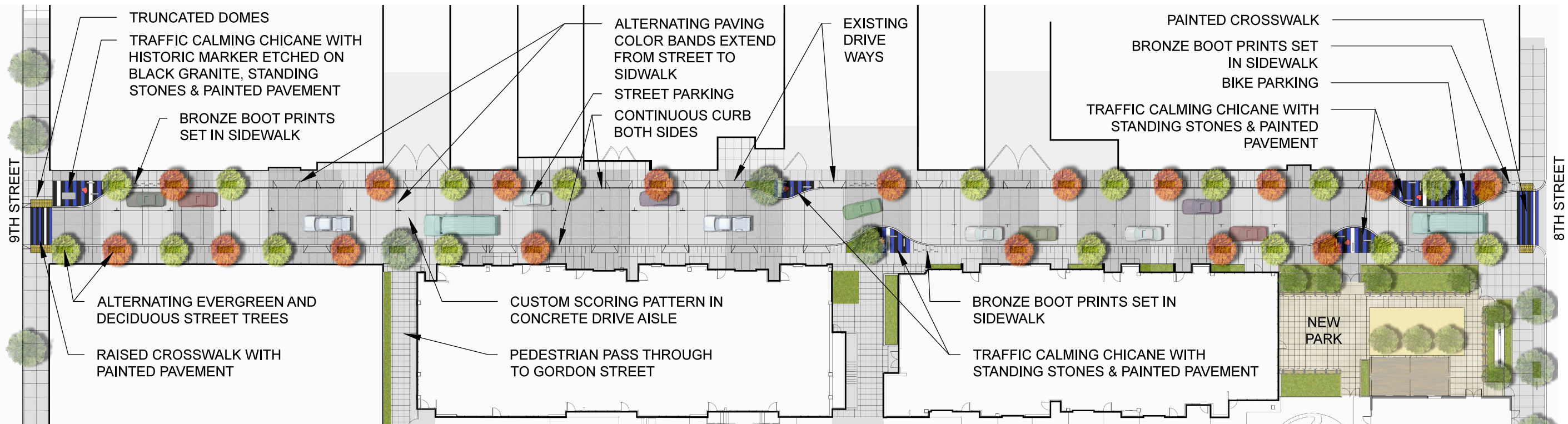

1 RINGOLD ALLEY LANDSCAPE PLAN  
SCALE: 1" = 40'-0"

RINGOLD HISTORY  
WALK  
SAN FRANCISCO, CA

NO.	DATE	REVISIONS
1	9/30/15	ARTS COMMISSION

PROJECT NO.	1314
DATE	SEPT. 30, 2015
SCALE	AS SHOWN

DRAWING TITLE  
**PLAN**

SHEET NO.  
**L1.0**



ENGRAVED CURBSTONE MARKERS  
(PRECEDENT IMAGE)



BRONZE BOOT PRINTS SET IN SIDE WALK  
(CONCEPT IMAGE)



LEATHER FLAG PATTERN PAINTED PAVEMENT AT 8TH & 9TH STREET CROSSWALKS & AT FOCAL POINTS ALONG ALLEY



FEATURE PAVEMENT AT CROSSWALKS  
(LOCAL PRECEDENT SHOWN)

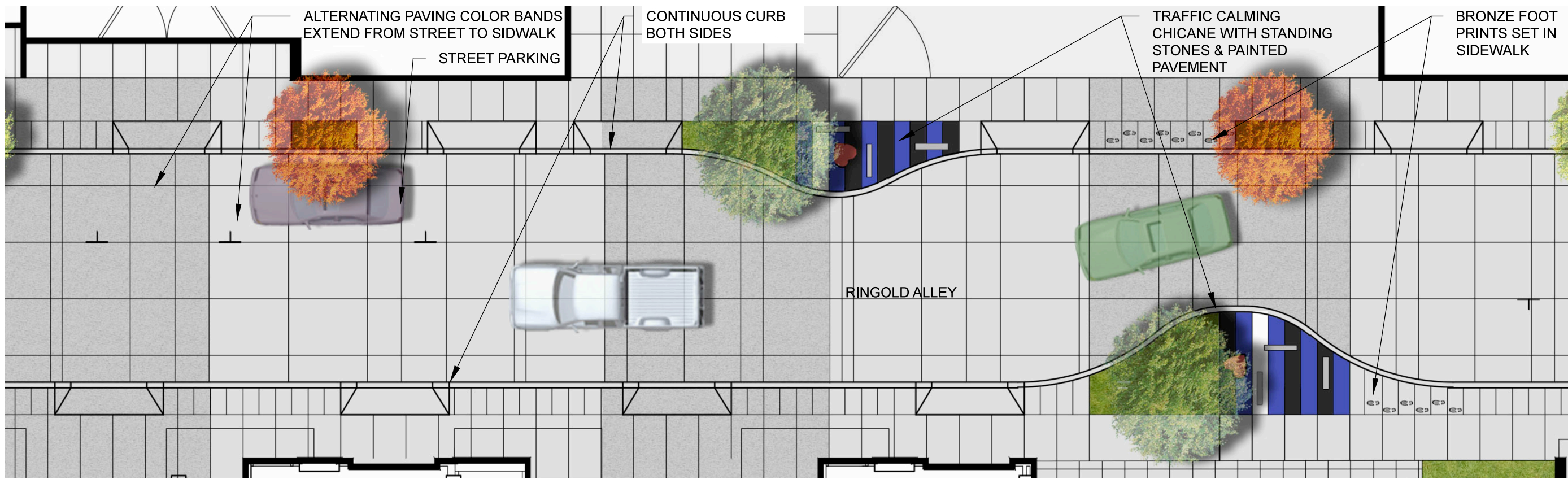

1 MID-BLOCK RINGOLD DETAIL PLAN  
SCALE: 1" = 10'-0"

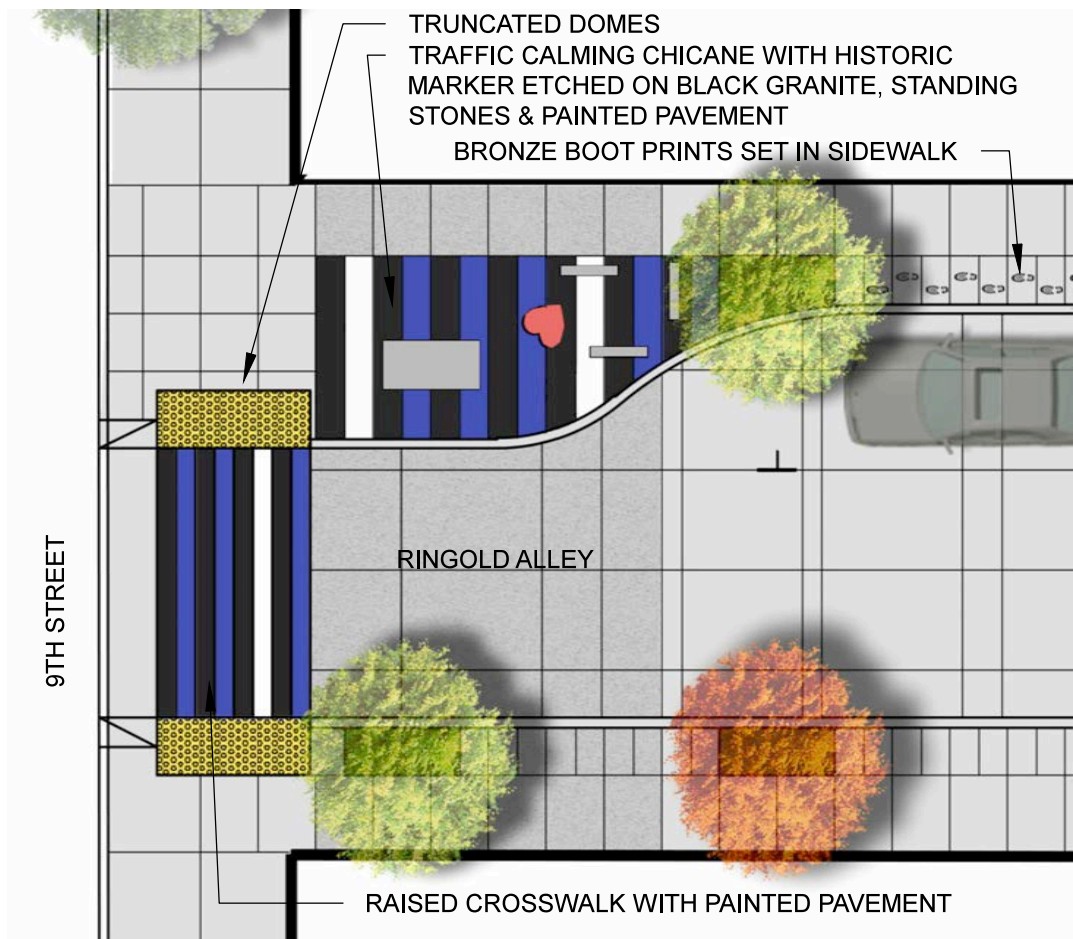

2 9TH STREET & RINGOLD DETAIL PLAN  
SCALE: 1" = 10'-0"

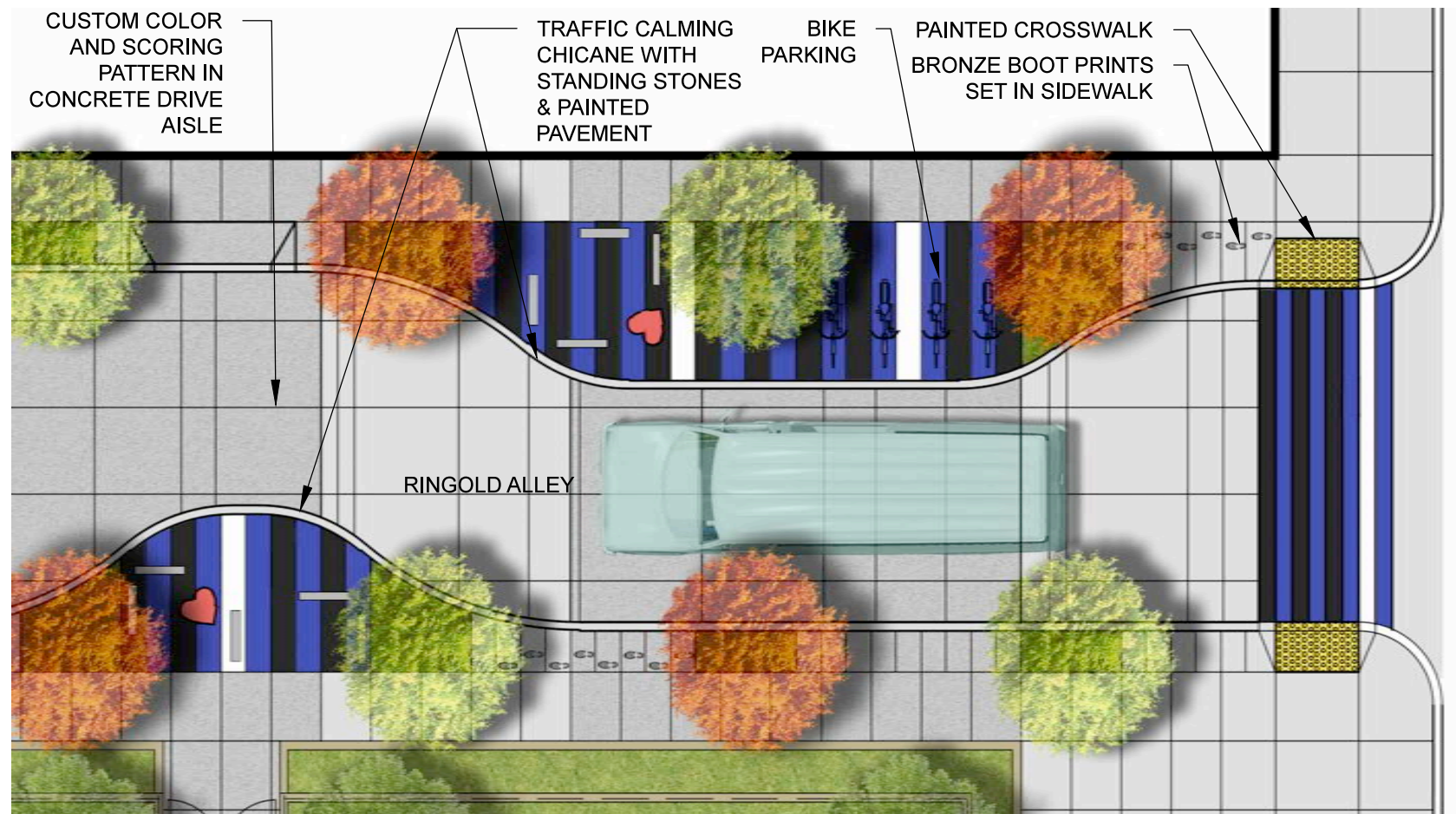

3 8TH STREET & RINGOLD DETAIL PLAN  
SCALE: 1" = 10'-0"

RINGOLD HISTORY  
WALK  
SAN FRANCISCO, CA

NO.	DATE	REVISIONS
1	9/30/15	ARTS COMMISSION

PROJECT NO.	1314
DATE	SEPT. 30, 2015
SCALE	AS SHOWN

DRAWING TITLE

AREA BLOWUPS

SHEET NO.  
**L1.1**

RINGOLD HISTORY  
WALK  
SAN FRANCISCO, CA

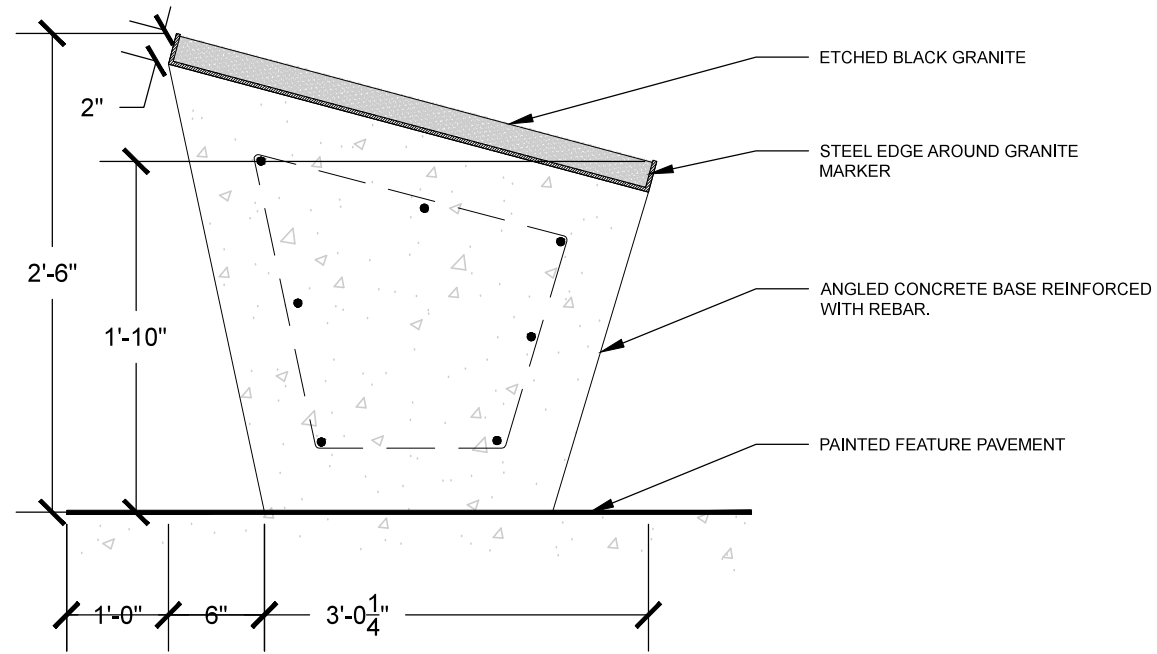

SECTION

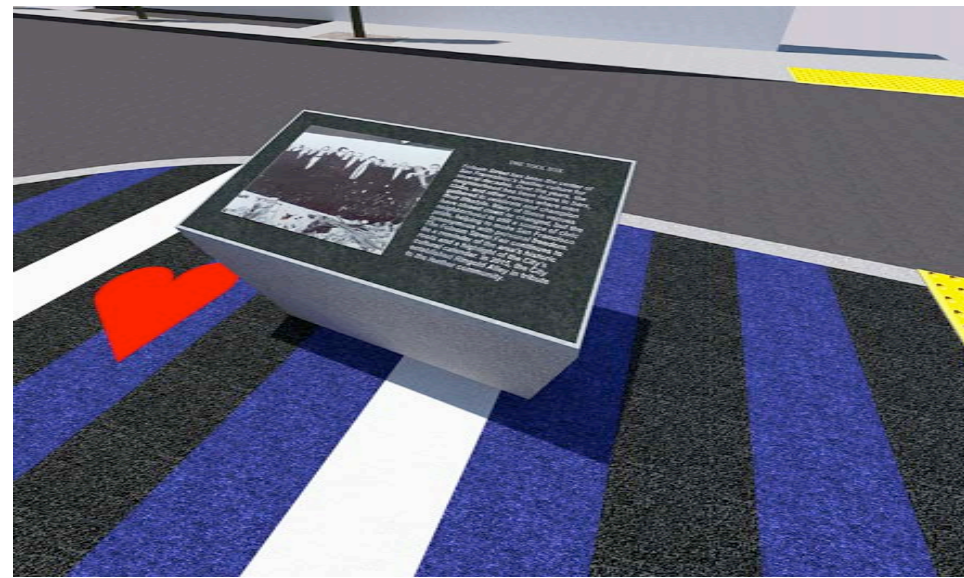

CONCEPT IMAGE: ETCHED BLACK GRANITE HISTORIC MARKER



THE TOOL BOX & MURAL: MID DEMOLITION

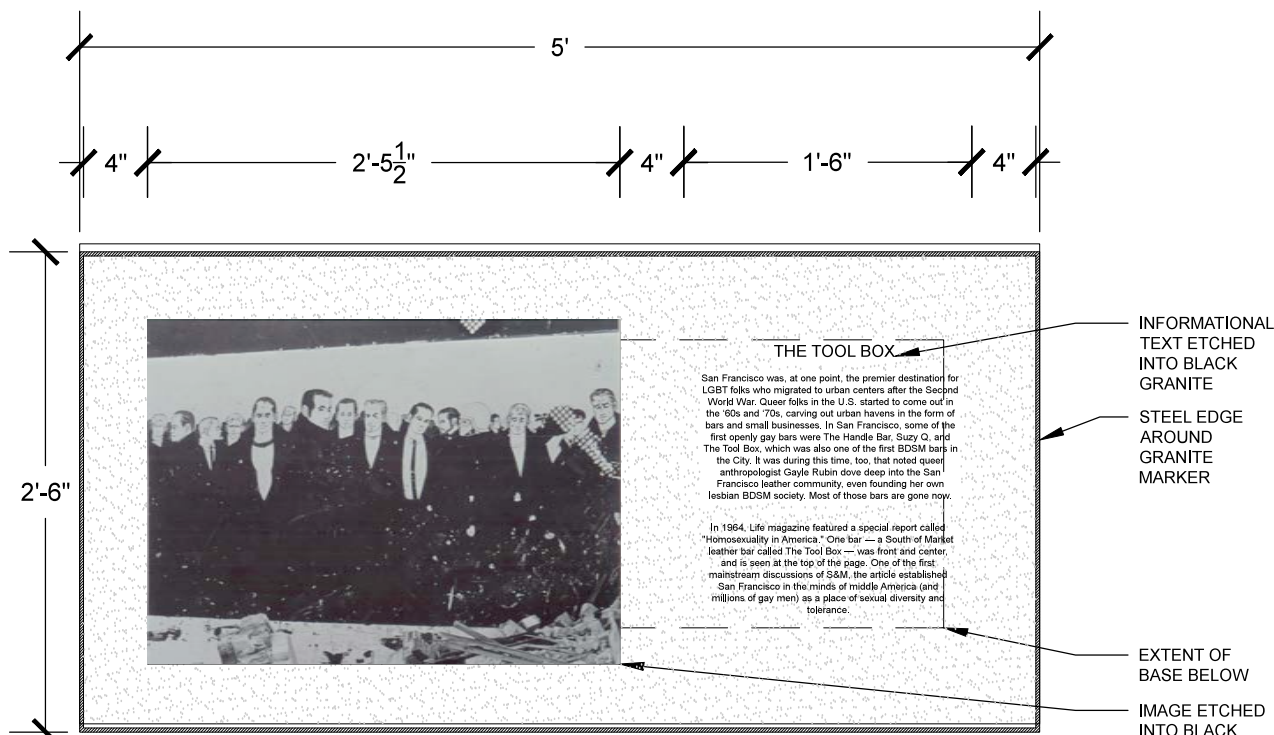

PLAN

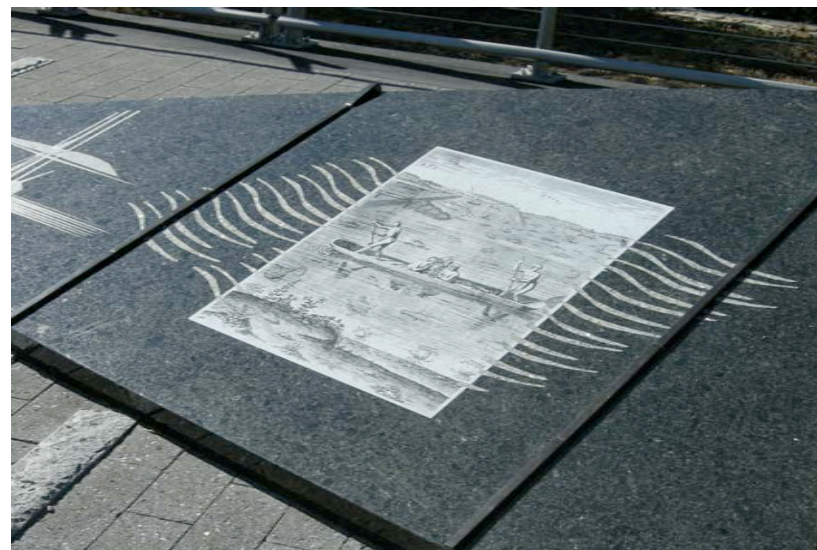

PRECEDENT IMAGE: ETCHED GRANITE MARKER

ETCHED BLACK GRANITE MARKER  
NEAR THE INTERSECTION OF 9TH  
AND RINGOLD FEATURING A  
REPLICA OF CHUCK ARNETT'S  
FAMOUS MURAL FROM THE TOOL  
BOX AND A BRIEF HISTORY OF  
THE NEIGHBORHOOD'S CULTURAL  
HISTORY

1 HISTORIC MARKER  
SCALE: 1"=1'-0"

NO.	DATE	REVISIONS
1	9/30/15	ARTS COMMISSION

PROJECT NO.	1314
DATE	SEPT. 30, 2015
SCALE	AS SHOWN

DRAWING TITLE  
DETAIL - HISTORIC MARKER

SHEET NO.  
L2.0



CONCEPT IMAGE: LEATHER PRIDE FLAG



PRECEDENT IMAGE: PAINTED BANDS



PRECEDENT IMAGE: PAINTED CONCRETE CROSSWALK

PAINTED SIDEWALKS AND CROSSWALKS LOCATED AS ILLUSTRATED AT VARIOUS LOCATIONS ALONG THE ALLEY INVOKE THE LEATHER PRIDE FLAG, PROVIDE VISUAL INTEREST, AND DEMARCATe AREAS DESIGNATED FOR GATHERING

**1 FEATURE PAVING**

NTS

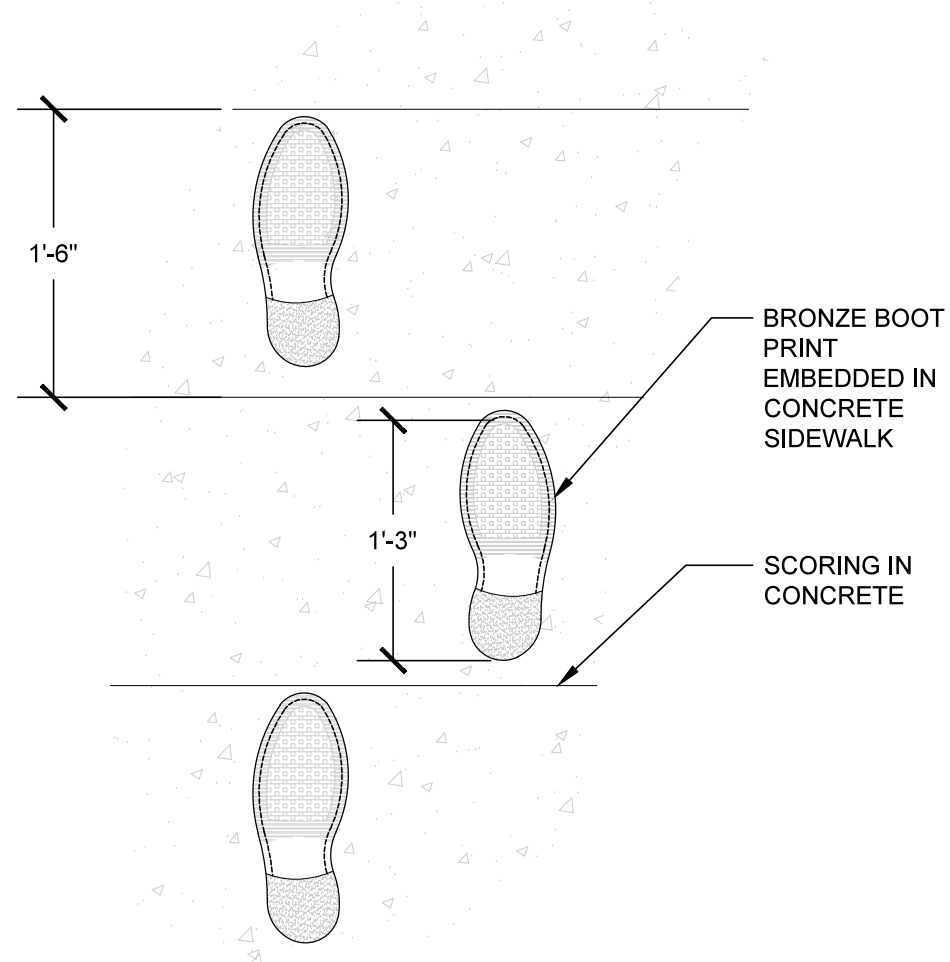

PRECEDENT IMAGE: DANCING STEPS, SEATTLE, WA



CONCEPT IMAGE: BRONZE BOOT PRINT

BRONZE FOOT PRINTS SET INTO THE SIDEWALK AT VARIOUS LOCATIONS ALONG RINGOLD ALLEY COMMEMORATE SOME OF THE KEY FIGURES WHO PLAYED A ROLE IN THE HISTORY OF FOLSOM'S GULCH

**2 EMBEDDED BRONZE BOOT PRINT**

SCALE: 1"=1'-0"

**RINGOLD HISTORY  
WALK  
SAN FRANCISCO, CA**

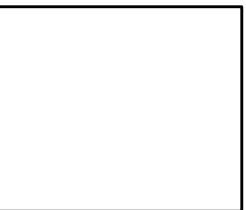

NO.	DATE	REVISIONS
1	9/30/15	ARTS COMMISSION

PROJECT NO.	1314
DATE	SEPT. 30, 2015
SCALE	AS SHOWN

DRAWING TITLE  
**DETAIL - PAINTED  
FEATURE PAVEMENT  
& BOOT PRINTS**

SHEET NO.  
**L2.1**

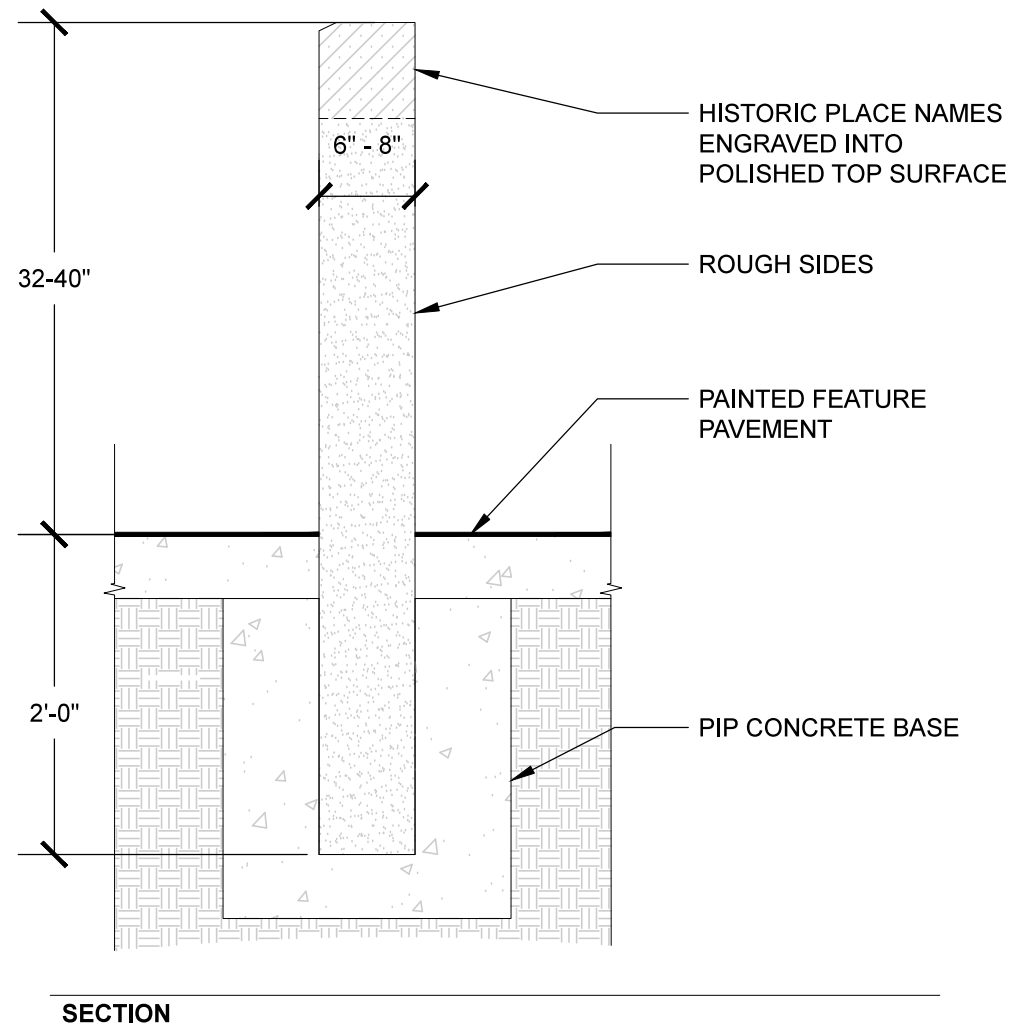
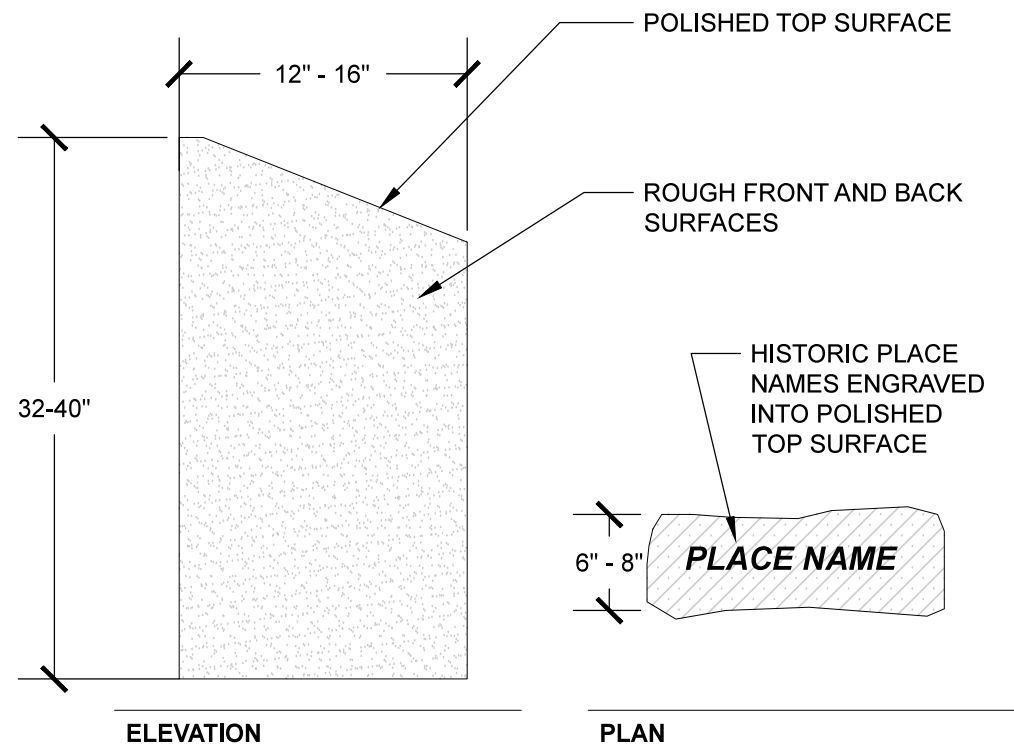

CONCEPT IMAGE: STANDING CURB STONES AT TRAFFIC CALMING CHICANE WITH PAINTED PAVEMENT



SALVAGED CURB STONE PIECES



PRECEDENT IMAGE: ENGRAVED STONE

SALVAGED CURBSTONE MARKERS WITH ROUGH FACES AND ENGRAVED, POLISHED TOPS COMMEMORATE IMPORTANT PLACES FROM THE NEIGHBORHOOD'S LGBTQ HERITAGE. USE OF OLD CURBSTONE PIECES CELEBRATES THE CITY'S HISTORY AND ACTIVATES DESIGNATED AREAS

RINGOLD HISTORY  
WALK  
SAN FRANCISCO, CA

NO.	DATE	REVISIONS
1	9/30/15	ARTS COMMISSION

PROJECT NO.	1314
DATE	SEPT. 30, 2015
SCALE	AS SHOWN

DRAWING TITLE  
DETAIL - STANDING CURB STONE

SHEET NO.  
L2.2

1 ENGRAVED STANDING CURB STONE  
SCALE: 1"=1'-0"

**Waiver of Proprietary Rights for Artwork Placed Upon City Property**

**Under VARA and CAPA**

Artist has designed a work of visual art. In consideration of the City’s approval of the Artist design of visual art.

DESCRIPTION: [type, mural, medium]:

Site specific installation in sidewalk and bulbout areas of Ringold Street between 8th and 9th Streets consisting of a photo etched black granite marker, engraved sierra granite recycled standing curbstones, bronze embeded bootprints, and pavement paint.

TITLED: Ringold History Walk

DIMENSIONS: Refer to drawings for dimensions of individual elements extending the length of the street.

LOCATED: Ringold Street between 8th and 9th Streets

(“the Work”) for the City artist agrees to waive and does hereby waive voluntarily all rights to attribution and integrity with respect to the Work and any and all claims as may arise under the Visual Artists Rights Act of 1990, 17 U.S.C. §§106A and 113(d) (“VARA”), the California Art Preservation Act (Cal. Civ. Code §§987 and 989 ) (“CAPA”), or any other local, state, foreign or international law, as currently drafted or as may be hereafter amended, that conveys the same or similar rights (“Moral Rights Laws”), with respect to the Work, its display, removal from display, exhibition, installation, conservation, storage, study, alteration and any other activities conducted by the City, its officers, employees, agents, contractors, licensees, successors or assigns. If the Work is incorporated into a building such that the Work cannot be removed from the building without physical defacement, mutilation, alternation, distortion, destruction, or other modification (collectively, “Modification”) of the Work, artist waives any and all such claims under any Moral Rights Laws arising out of or against any current or future owners of the site, and its agents, officers and employees, for Modification of the Work.

The City has the absolute right to change, modify, destroy, remove, relocate, move, replace, transport, repair or restore the Work, in whole or in part, in City’s sole discretion.

The City has no obligation to pursue claims against third parties for modifications or damage to the Work done without the City’s authorization. However, the City may pursue claims against third parties for modifications or damage or to restore the Work if the work has been modified without the City’s authorization. In the event that the City pursues such a claim, it shall notify the Artist, and Artist shall cooperate with the City’s efforts to prosecute such claims.

If the City modifies the Artwork without the Artist’s consent in a manner that is prejudicial to Artist’s reputation, Artist retains the right to disclaim authorship of the Artwork in accordance with 17 U.S.C. § 106A (a) (2).



Artist bears the sole responsibility for providing the City with any changes to the Artist's Address for Notice. Notice of changes must be mailed to the Arts Commission, 401 Van Ness Avenue, Suite 325, San Francisco, CA 94102 and to the City Agency with jurisdiction over the property:

Agency Contact \_\_\_\_\_

City Agency \_\_\_\_\_

Address \_\_\_\_\_

Phone Number \_\_\_\_\_ Email \_\_\_\_\_

Artist understands the effect of this waiver and hereby acknowledges that Artist is surrendering the rights described herein with respect to the Work.

Artist Signature: \_\_\_\_\_

Artist Name: \_\_\_\_\_ Date: \_\_\_\_\_

Address: \_\_\_\_\_

Phone: \_\_\_\_\_ Email \_\_\_\_\_

By: ARTS COMMISSION

Name: \_\_\_\_\_ Date: \_\_\_\_\_

Title: \_\_\_\_\_ Phone: \_\_\_\_\_

- See more at: <http://www.sfartscommission.org/pubartcollection/waiver-of-proprietary-rights-for-artwork-placed-upon-city-property/#sthash.ybg5huEe.dpuf>