

**GTU RELOCATION PROJECT  
TERMINAL 1 REDEVELOPMENT PROGRAM  
SAN FRANCISCO INTERNATIONAL AIRPORT**

**CIVIC DESIGN PRESENTATION:  
PHASE 2 DESIGN DEVELOPMENT  
& PHASE 3 CONSTRUCTION DOCUMENTS (FUEL & WASH STATION)  
JANUARY 11, 2016**



mwa architects



PAULETT TAGGART  
ARCHITECTS

# SOUTH FIELD RELOCATION



- PHASE I (THIS PROJECT)**
- TEMPORARY GTU OFFICES & INSPECTION BAYS
  - FUELING STATION
  - CAR WASH FACILITY

- PHASE II (THIS PROJECT)**
- GTU FACILITY

- PHASE III (FUTURE PROJECT)**
- BUS MAINTENANCE FACILITY
  - CNG FACILITY



mwa architects





## EXISTING SOUTH FIELD FACILITIES

Ground Transportation Unit



Car Wash Facility



Fueling Station



mwa architects



CIVIC DESIGN PRESENTATION: PHASE 2 DESIGN DEVELOPMENT & PHASE 3 CONSTRUCTION DOCUMENTS  
JANUARY 11, 2016

GTU RELOCATION PROJECT  
TERMINAL 1 REDEVELOPMENT PROGRAM  
SAN FRANCISCO INTERNATIONAL AIRPORT

PAULETT TAGGART  
ARCHITECTS



# EXISTING SITE



mwa architects



CIVIC DESIGN PRESENTATION: PHASE 2 DESIGN DEVELOPMENT & PHASE 3 CONSTRUCTION DOCUMENTS  
JANUARY 11, 2016

GTU RELOCATION PROJECT  
TERMINAL 1 REDEVELOPMENT PROGRAM  
SAN FRANCISCO INTERNATIONAL AIRPORT

PAULETT TAGGART  
ARCHITECTS

## EXISTING SITE

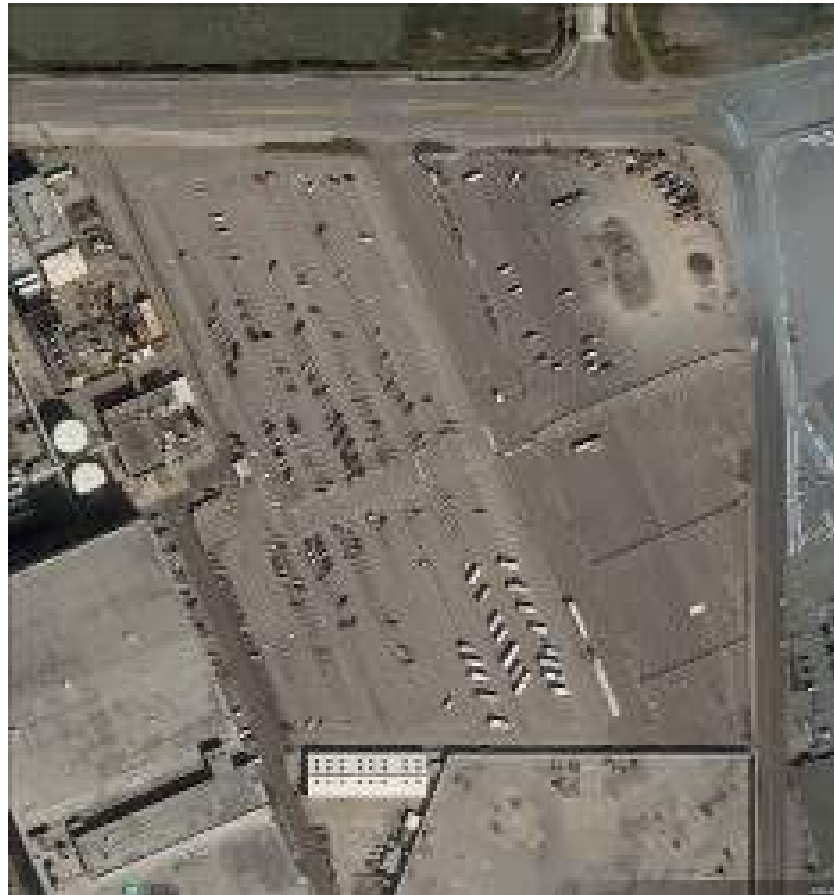

AERIAL VIEW



VIEW FROM NORTHEAST CORNER OF SITE



mwa architects



CIVIC DESIGN PRESENTATION: PHASE 2 DESIGN DEVELOPMENT & PHASE 3 CONSTRUCTION DOCUMENTS  
JANUARY 11, 2016

GTU RELOCATION PROJECT  
TERMINAL 1 REDEVELOPMENT PROGRAM  
SAN FRANCISCO INTERNATIONAL AIRPORT

PAULETT TAGGART  
ARCHITECTS



# SITE PLAN

## DIAGRAM KEY

- 1 TEMPORARY GTU OFFICES
- 2 TEMPORARY INSPECTION BAY & RADIO SHOP BAY
- 3 VEHICLE WASH
- 4 CCSF FUELING STATION
- 5 FUEL STORAGE TANKS
- 6 PERMANENT GTU OFFICES
- 7 PERMANENT GTU INSPECTION BAY
- 8 PERMANENT RADIO SHOP BAY
- 9 BUS PARKING
- 10 STAFF PARKING
- 11 CUSTOMER PARKING
- 12 PARCEL BOUNDARY
- 13 AOA BOUNDARY
- 14 PAD-MOUNTED UTILITIES
- 15 TEMPORARY CONSTRUCTION FENCE
- 16 EXISTING FENCE
- 17 PAINTED STRIPING

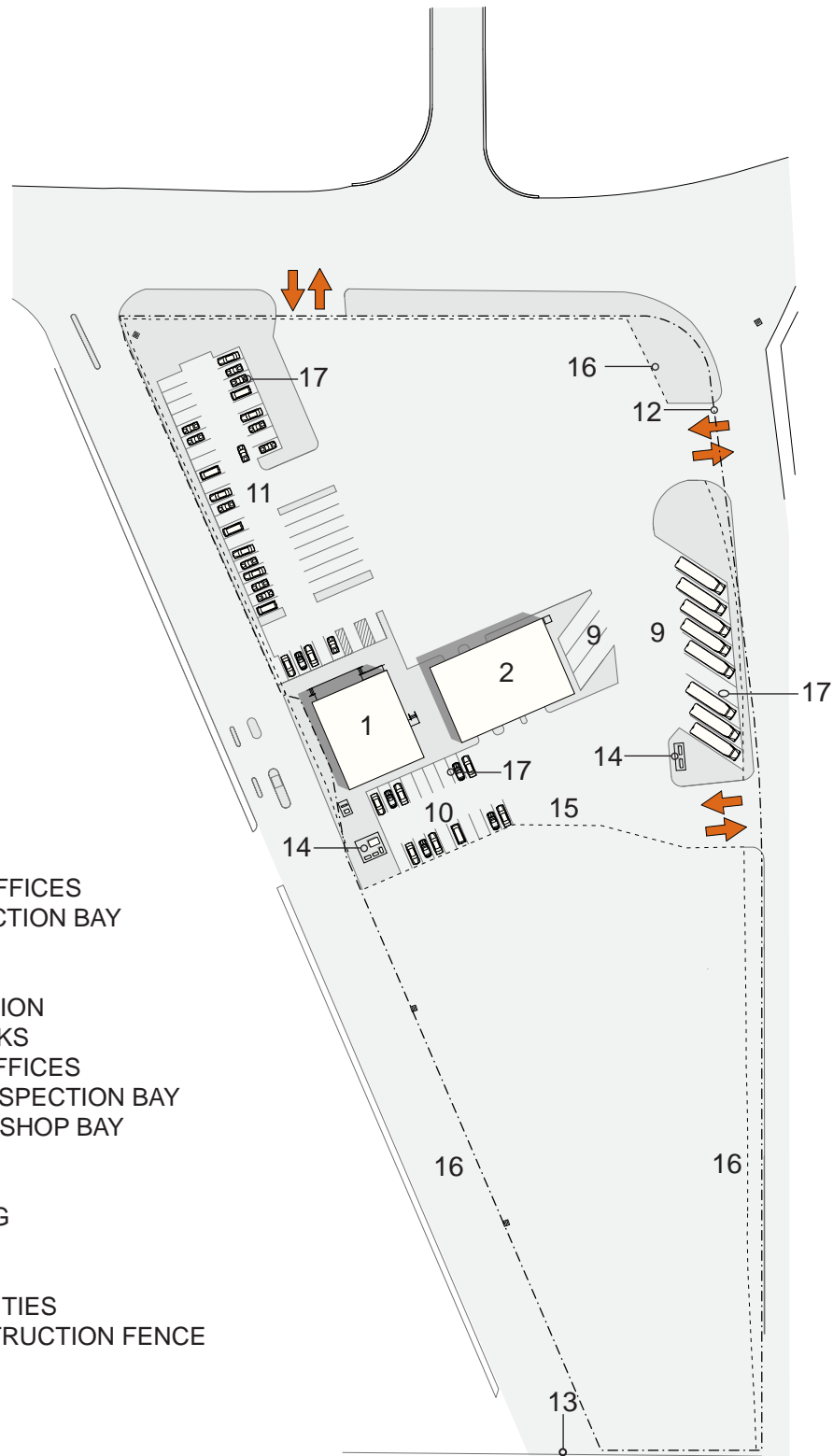

PHASE IA

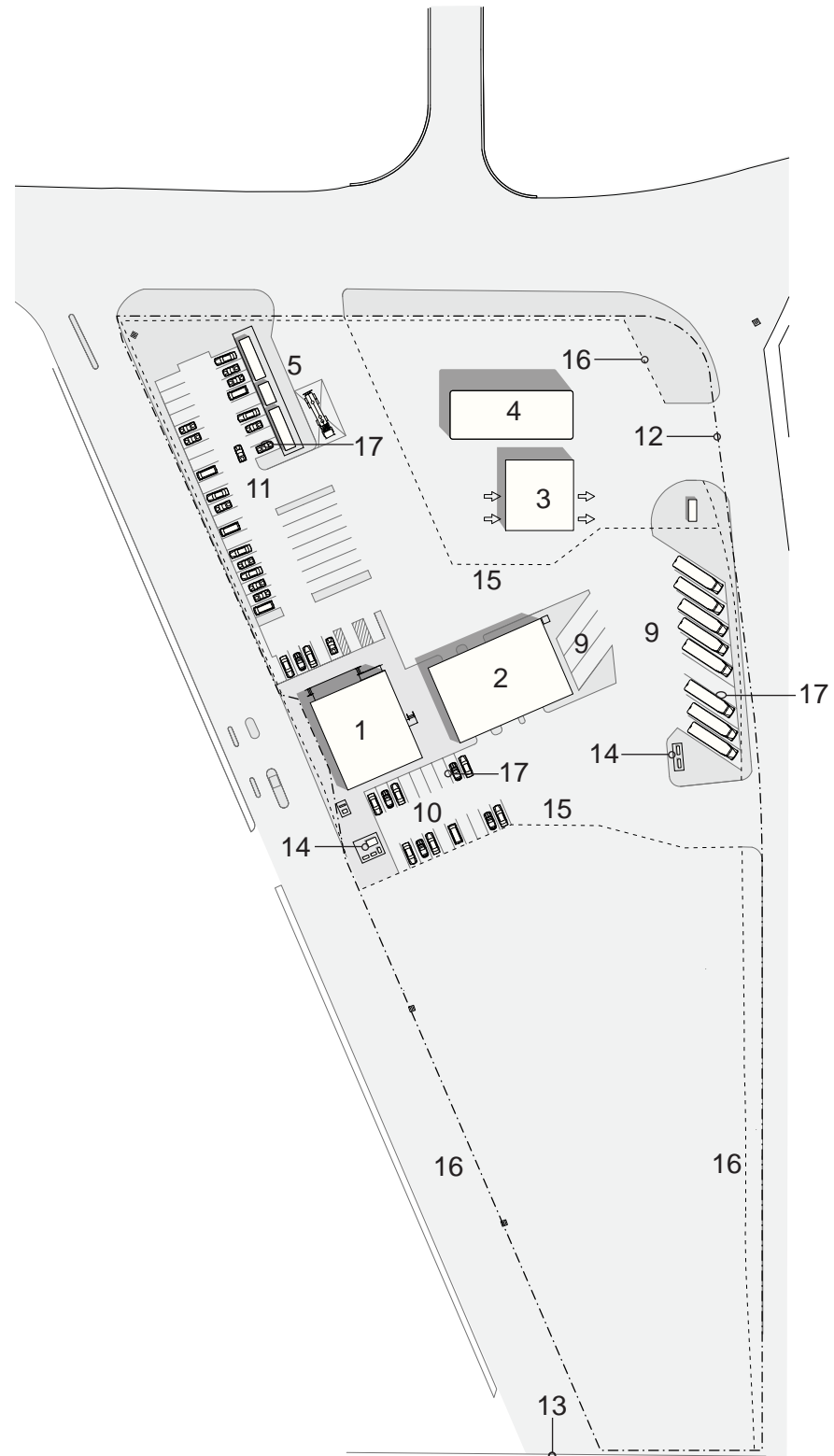

PHASE IB

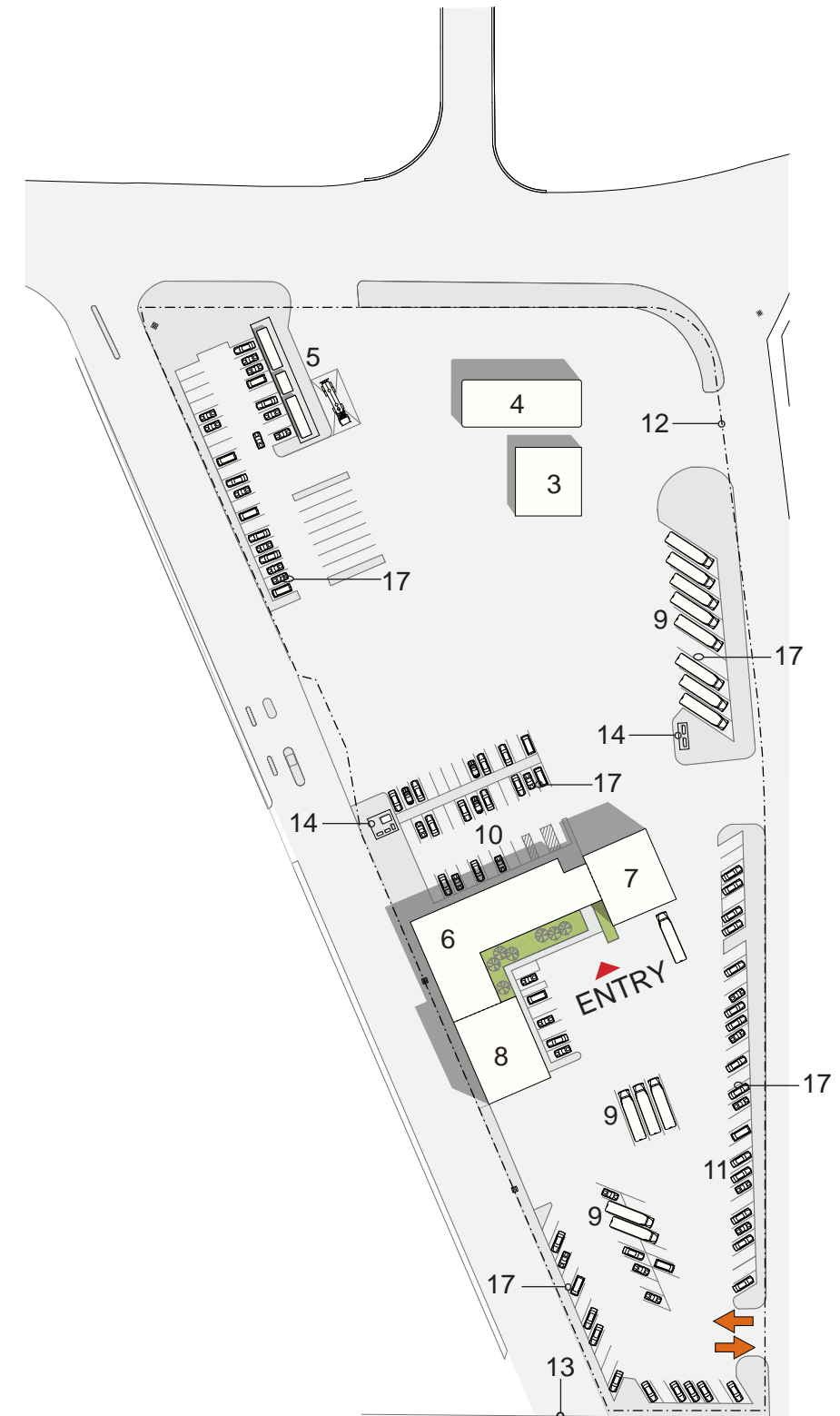

PHASE II

**GTU RELOCATION PROJECT  
TERMINAL 1 REDEVELOPMENT PROGRAM  
SAN FRANCISCO INTERNATIONAL AIRPORT**



**mwa architects**



**CIVIC DESIGN PRESENTATION: PHASE 2 DESIGN DEVELOPMENT & PHASE 3 CONSTRUCTION DOCUMENTS**  
JANUARY 11, 2016

**PAULETT TAGGART**  
ARCHITECTS

# SITE PLAN: PHASE II

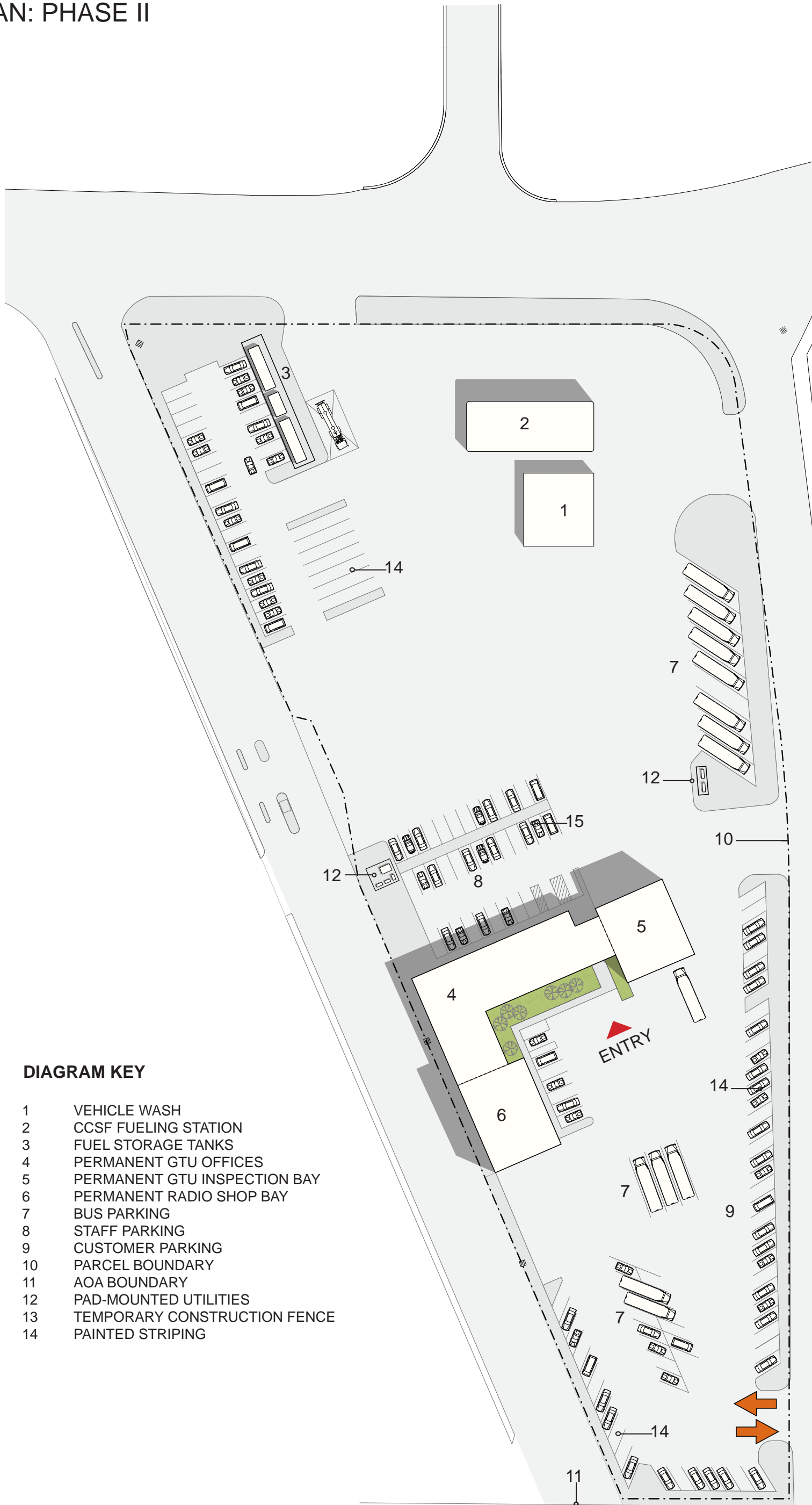

## DIAGRAM KEY

- 1 VEHICLE WASH
- 2 CCSF FUELING STATION
- 3 FUEL STORAGE TANKS
- 4 PERMANENT GTU OFFICES
- 5 PERMANENT GTU INSPECTION BAY
- 6 PERMANENT RADIO SHOP BAY
- 7 BUS PARKING
- 8 STAFF PARKING
- 9 CUSTOMER PARKING
- 10 PARCEL BOUNDARY
- 11 AOA BOUNDARY
- 12 PAD-MOUNTED UTILITIES
- 13 TEMPORARY CONSTRUCTION FENCE
- 14 PAINTED STRIPING

**GTU RELOCATION PROJECT  
TERMINAL 1 REDEVELOPMENT PROGRAM  
SAN FRANCISCO INTERNATIONAL AIRPORT**



**mwa architects**



**PAULETT TAGGART  
ARCHITECTS**



mwa architects



CIVIC DESIGN PRESENTATION: PHASE 2 DESIGN DEVELOPMENT & PHASE 3 CONSTRUCTION DOCUMENTS  
JANUARY 11, 2016

GTU RELOCATION PROJECT  
TERMINAL 1 REDEVELOPMENT PROGRAM  
SAN FRANCISCO INTERNATIONAL AIRPORT

PAULETT TAGGART  
ARCHITECTS



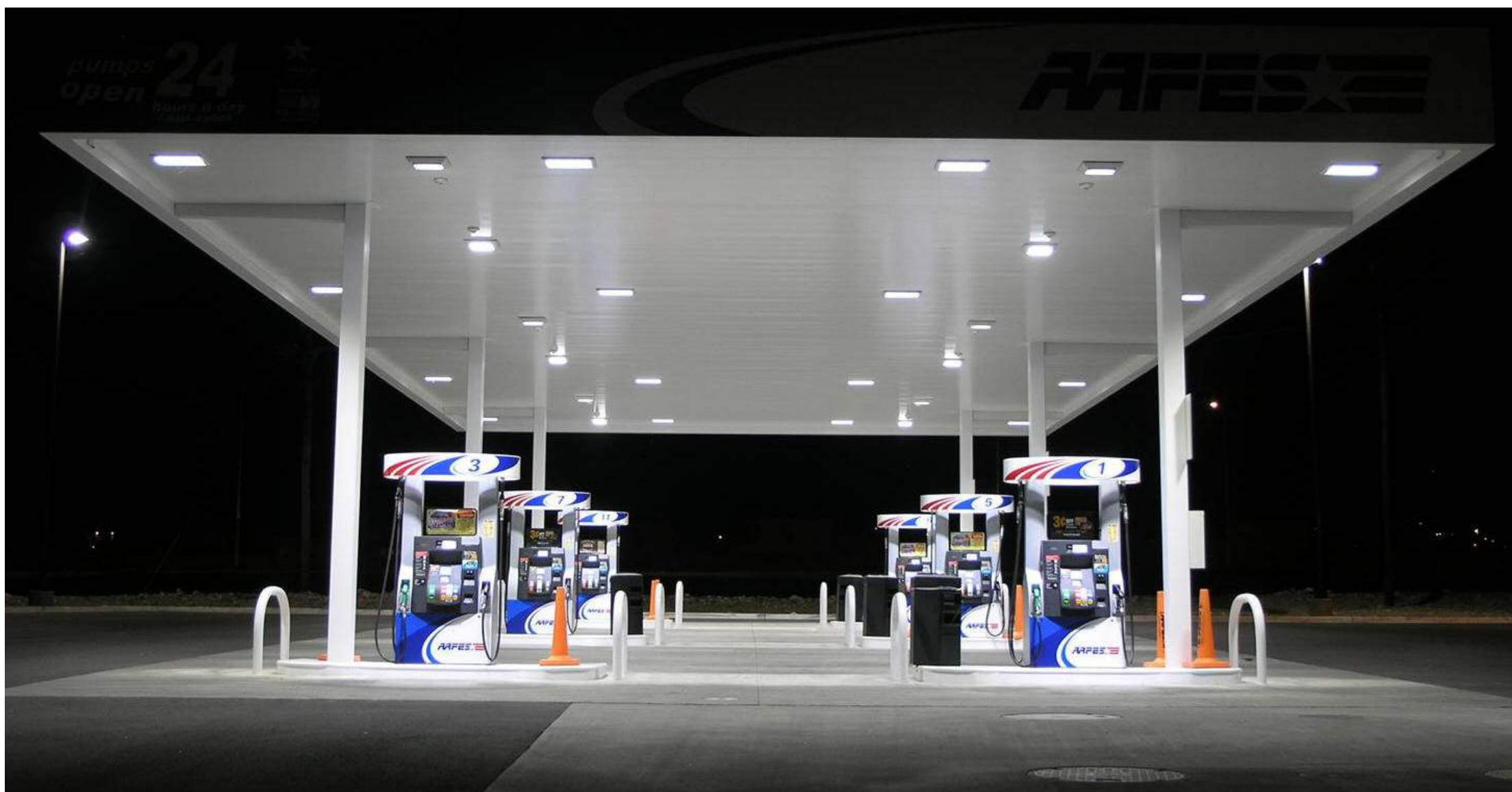

mwa architects



CIVIC DESIGN PRESENTATION: PHASE 2 DESIGN DEVELOPMENT & PHASE 3 CONSTRUCTION DOCUMENTS  
JANUARY 11, 2016

GTU RELOCATION PROJECT  
TERMINAL 1 REDEVELOPMENT PROGRAM  
SAN FRANCISCO INTERNATIONAL AIRPORT

PAULETT TAGGART  
ARCHITECTS

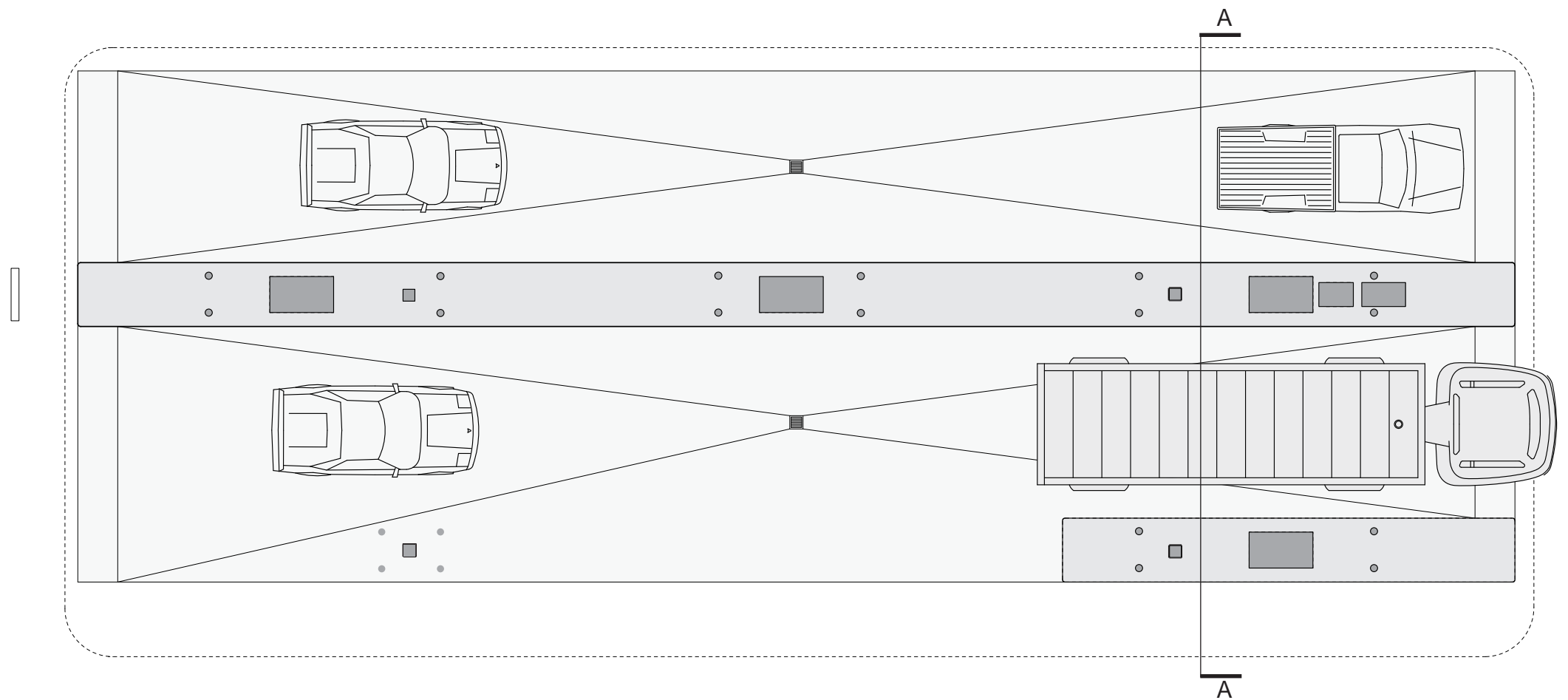

Fueling Station Plan

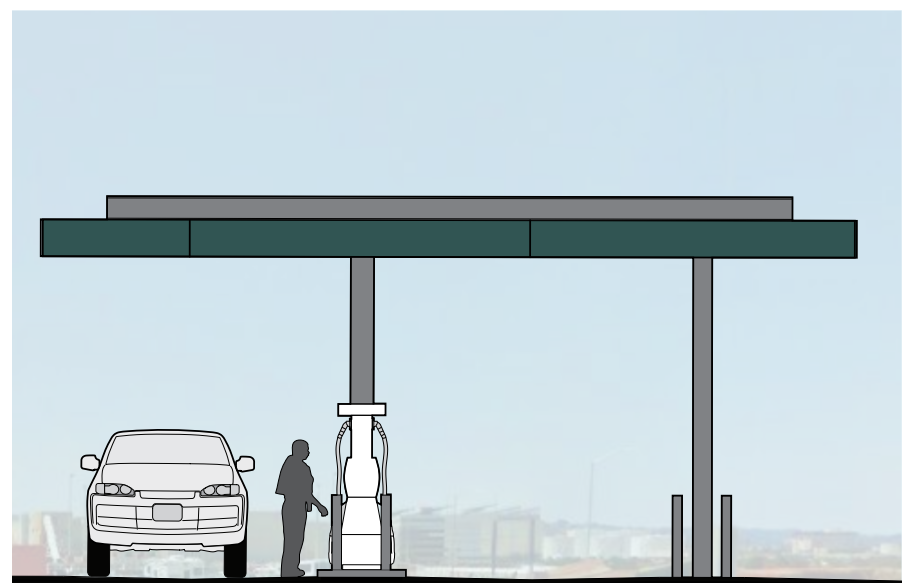
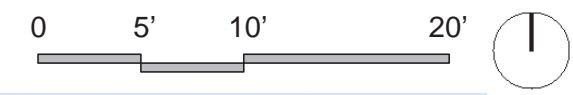

Fueling Station Elevation

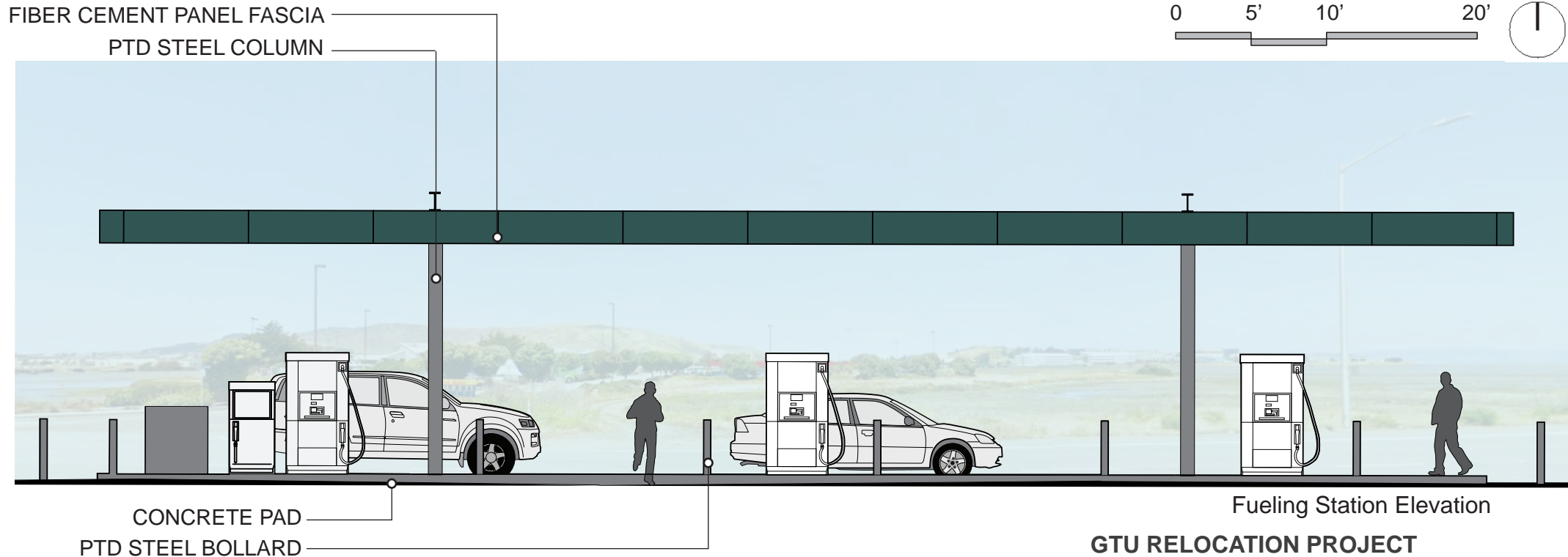

Fueling Station Elevation



mwa architects



CIVIC DESIGN PRESENTATION: PHASE 2 DESIGN DEVELOPMENT & PHASE 3 CONSTRUCTION DOCUMENTS  
JANUARY 11, 2016

GTU RELOCATION PROJECT  
TERMINAL 1 REDEVELOPMENT PROGRAM  
SAN FRANCISCO INTERNATIONAL AIRPORT

PAULETT TAGGART  
ARCHITECTS



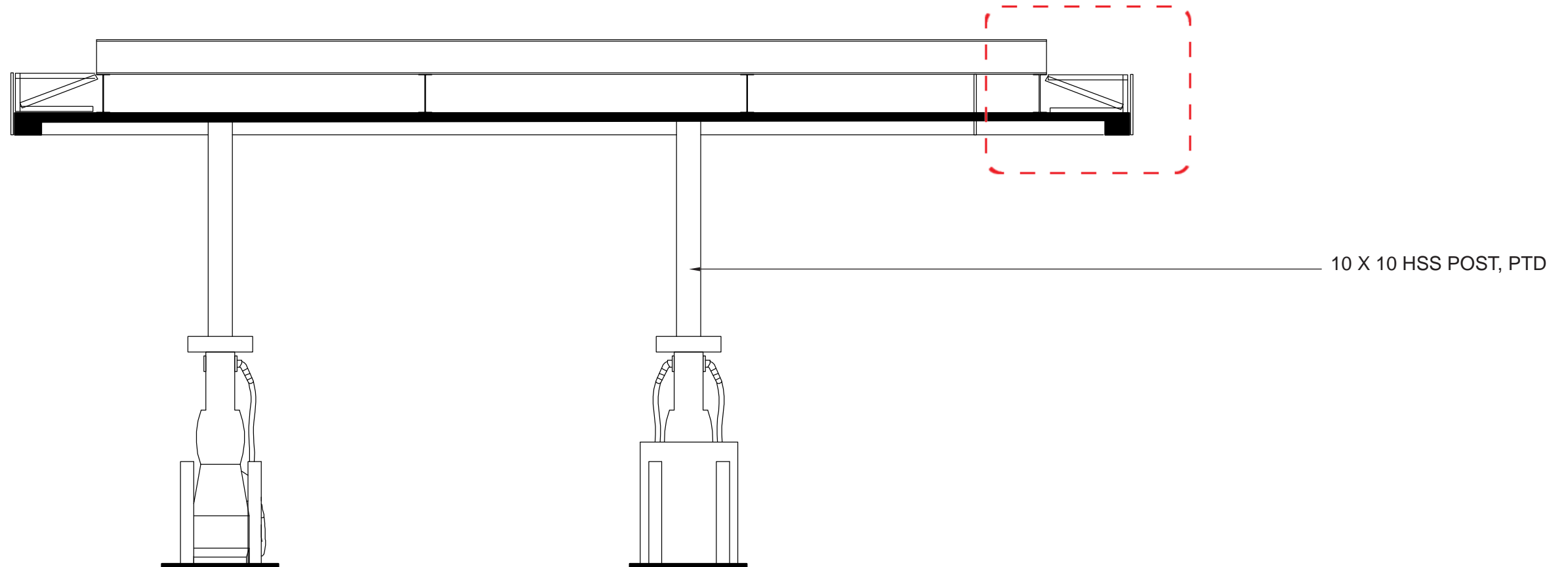
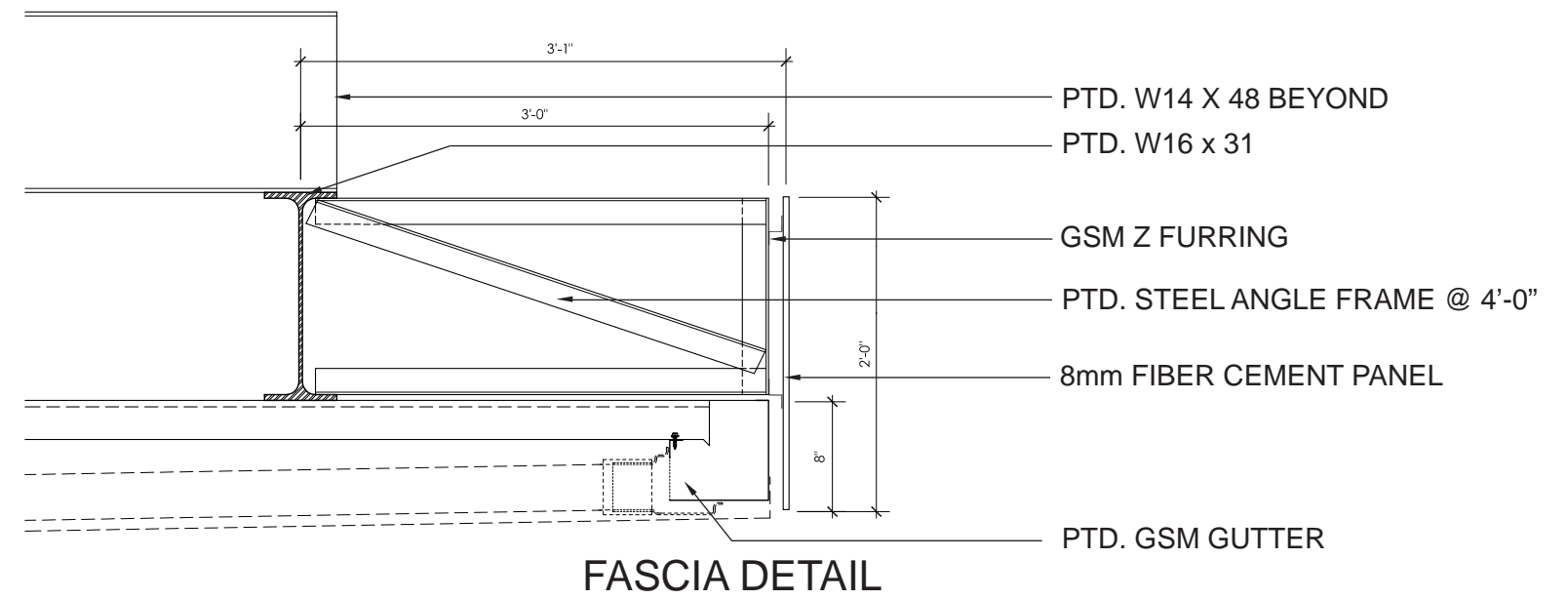

Section A

**SECTION THROUGH FUEL STATION**

**GTU RELOCATION PROJECT  
TERMINAL 1 REDEVELOPMENT PROGRAM  
SAN FRANCISCO INTERNATIONAL AIRPORT**



**mwa architects**



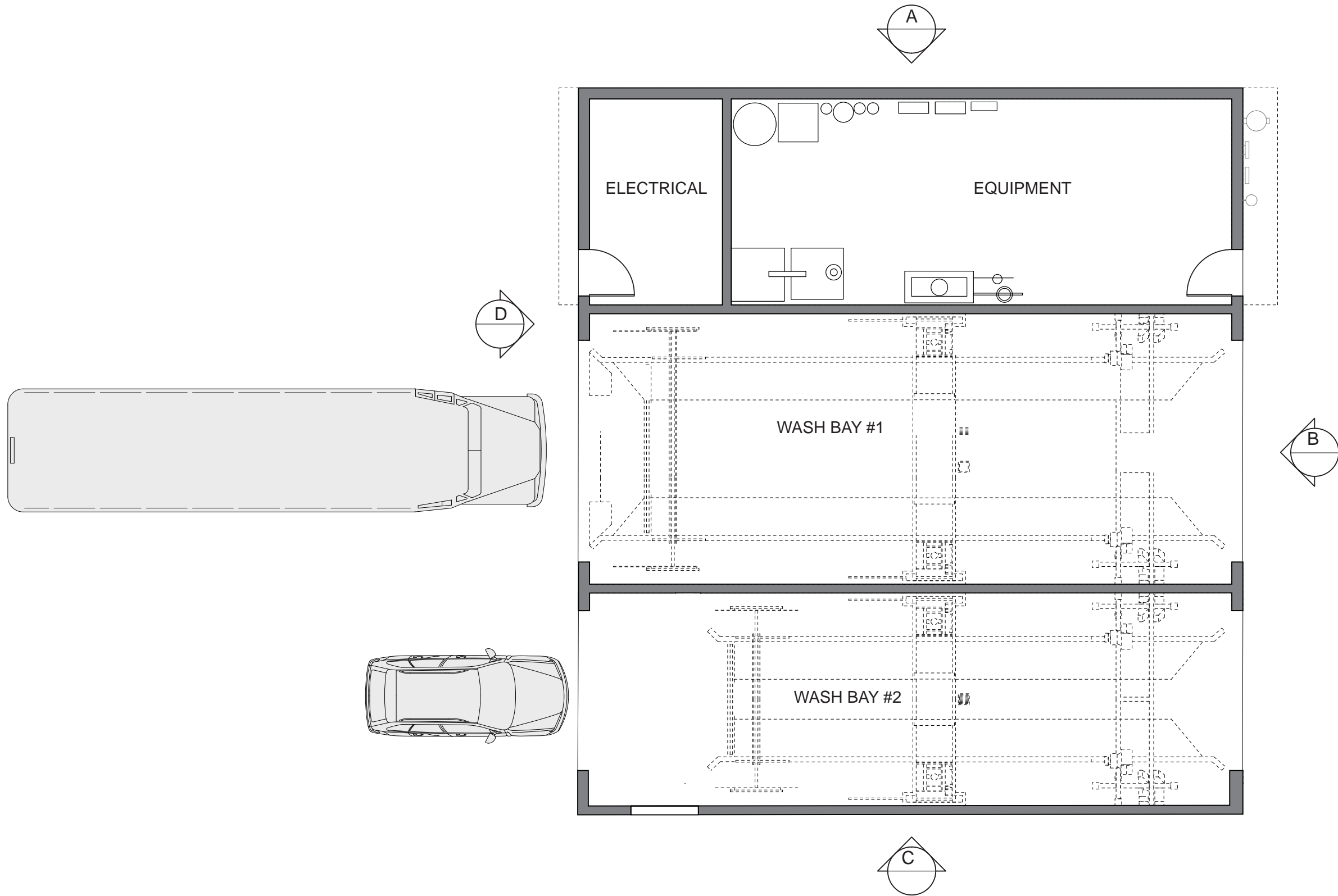

PLAN AT WASH STATION

GTU RELOCATION PROJECT  
 TERMINAL 1 REDEVELOPMENT PROGRAM  
 SAN FRANCISCO INTERNATIONAL AIRPORT



mwa architects



CIVIC DESIGN PRESENTATION: PHASE 2 DESIGN DEVELOPMENT & PHASE 3 CONSTRUCTION DOCUMENTS  
 JANUARY 11, 2016

PAULETT TAGGART  
 ARCHITECTS



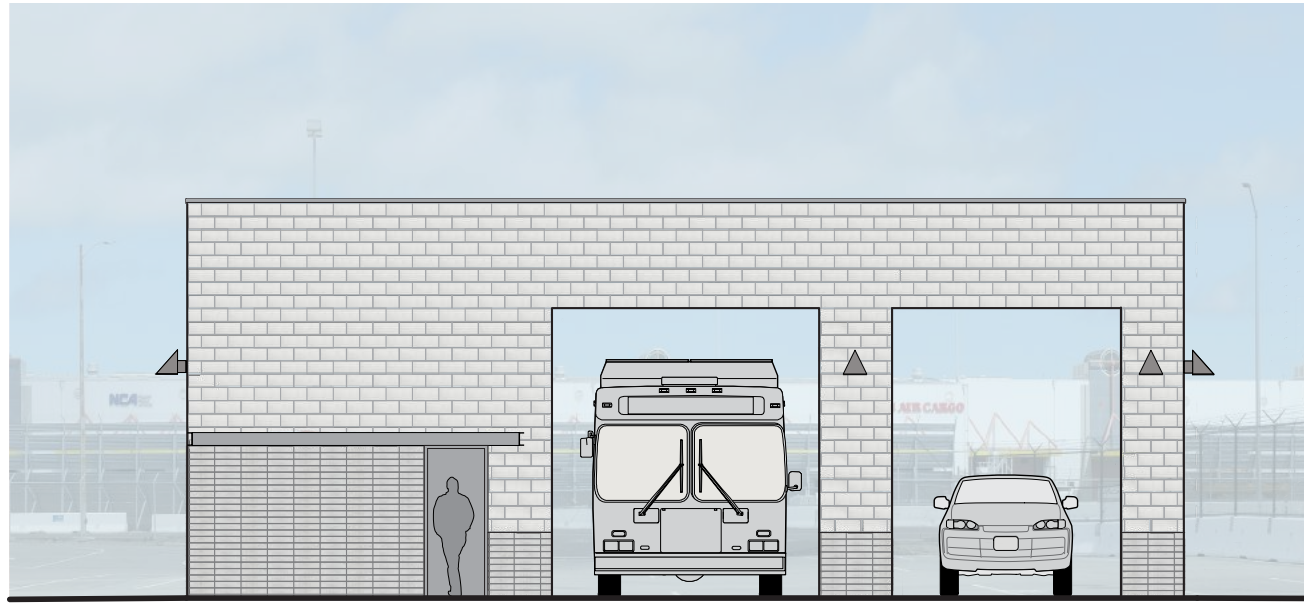

Vehicle Wash West Elevation (D)

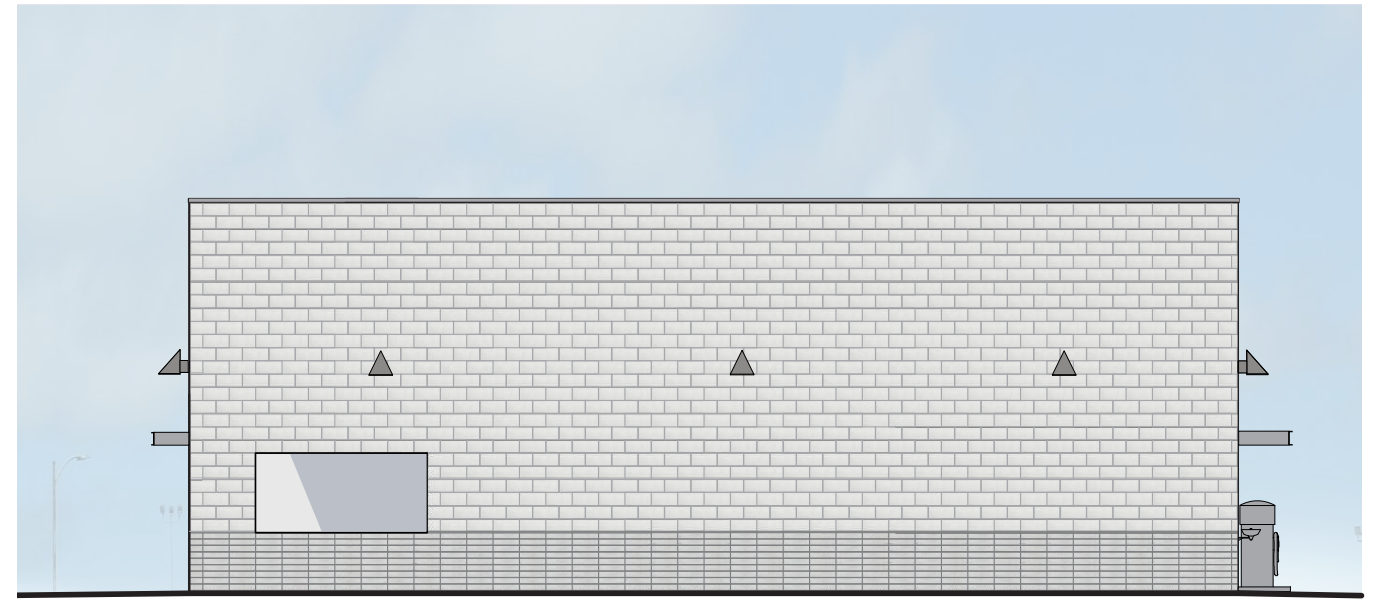

Vehicle Wash South Elevation (C)

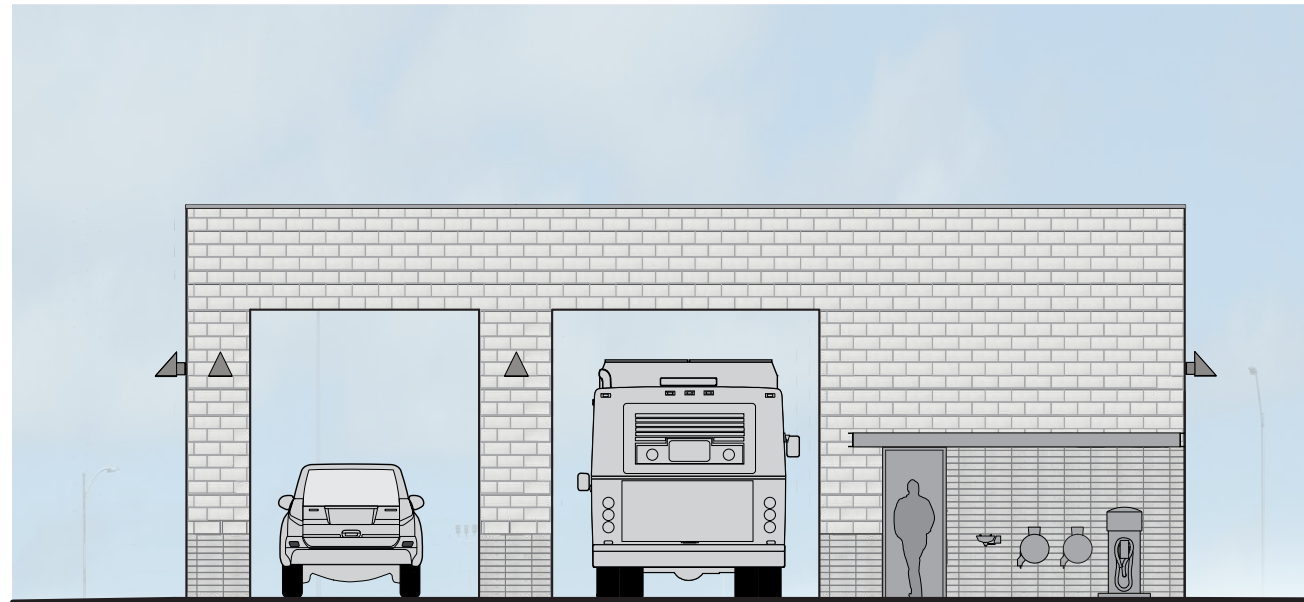

Vehicle Wash East Elevation (B)

- PTD MTL COPING
- PTD ALUM LOUVER
- GROUND-FACE CMU
- PTD STEEL CANOPY
- GROUND FACE CMU
- S.S. EQUIPMENT

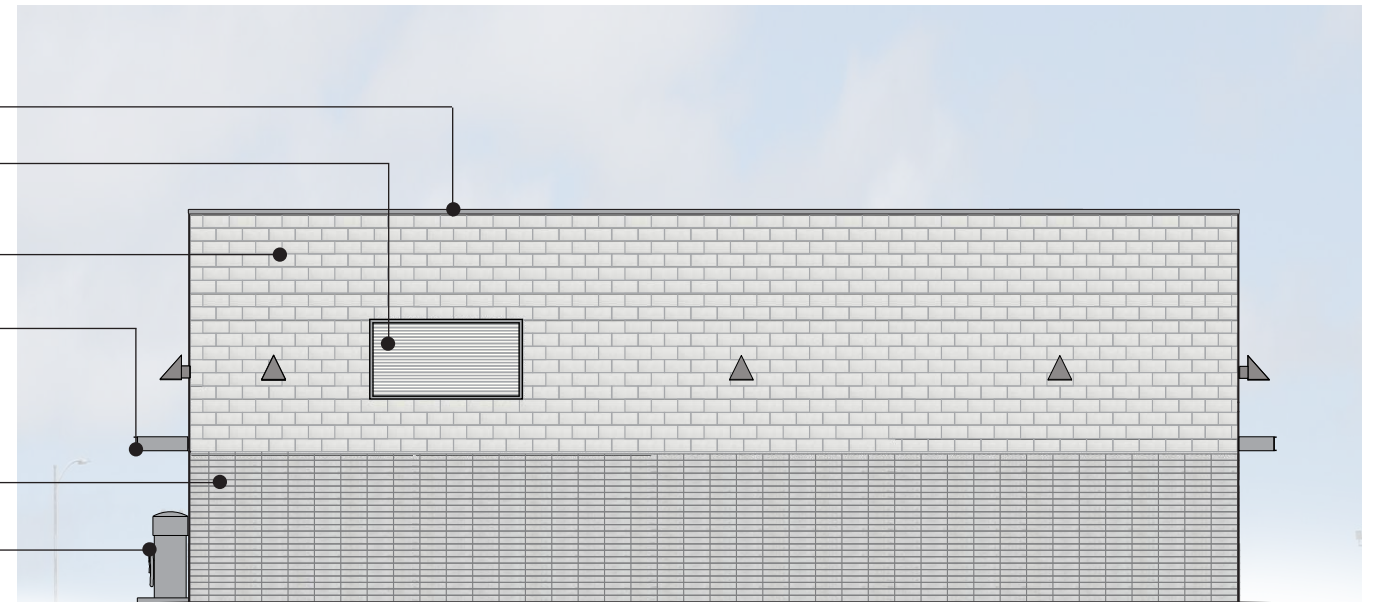

Vehicle Wash North Elevation (A)



mwa architects



CIVIC DESIGN PRESENTATION: PHASE 2 DESIGN DEVELOPMENT & PHASE 3 CONSTRUCTION DOCUMENTS  
JANUARY 11, 2016

GTU RELOCATION PROJECT  
TERMINAL 1 REDEVELOPMENT PROGRAM  
SAN FRANCISCO INTERNATIONAL AIRPORT

PAULETT TAGGART  
ARCHITECTS

# 12,000 UL2085 FIREGUARD TANK

MATERIAL AND CONSTRUCTION CONFORM TO INTERPRETED LABORATORY STANDARD U.L. 2085. SECONDARY CONTAINMENT PROTECTED ABOVEGROUND TANK. FIRE RESISTANT PER U.L. 2085. BALLISTIC RESISTANT PER U.L. 2085. VEHICLE IMPACT RESISTANT PER U.L. 2085. U.L. LABEL FOR PROTECTED SECONDARY CONTAINMENT ABOVEGROUND TANK IS REQUIRED. CARB EXECUTIVE ORDER VR-302.C.

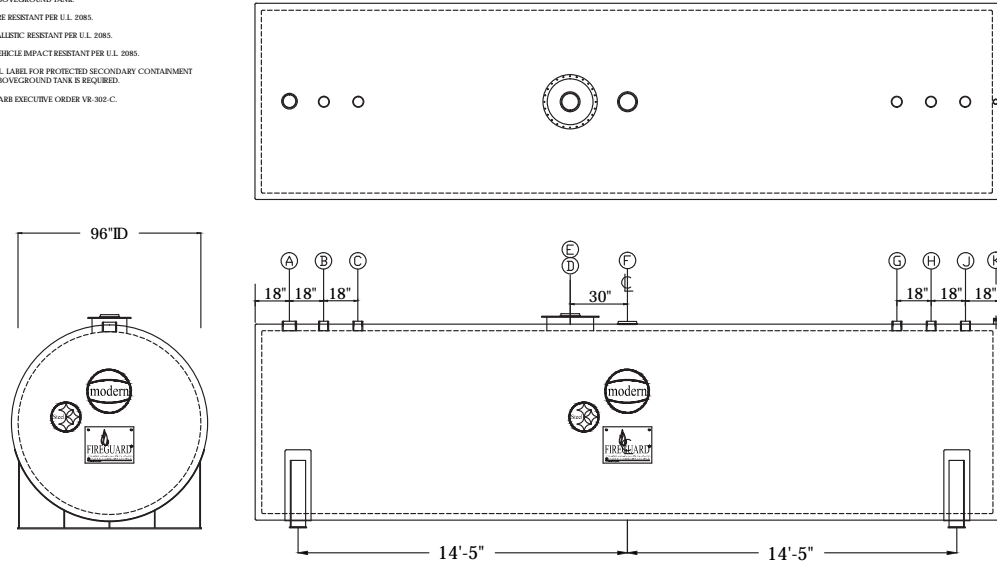

# SOLID STATE AREA LIGHTING RAZAR SERIES-LED SPECIFICATIONS

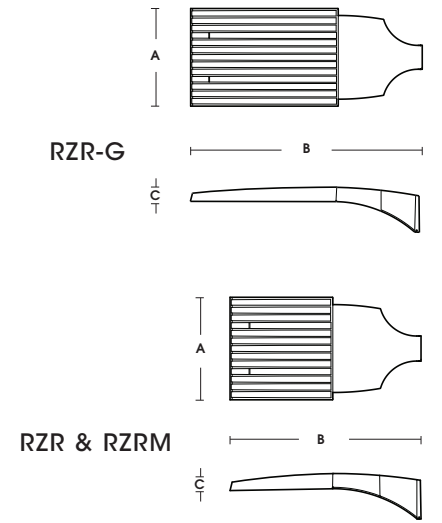

# Mitre™ LED-M2



## SPECIFICATIONS

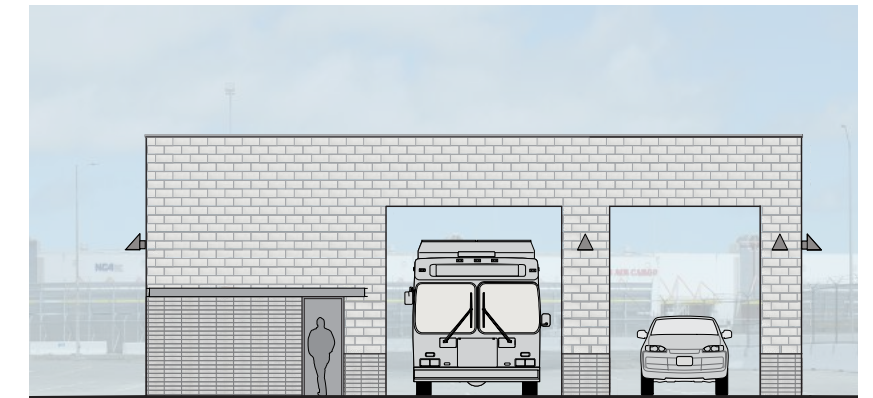
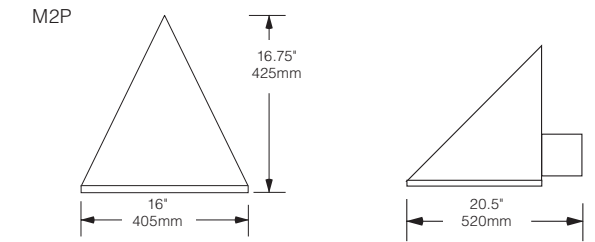

mwa architects



CIVIC DESIGN PRESENTATION: PHASE 2 DESIGN DEVELOPMENT & PHASE 3 CONSTRUCTION DOCUMENTS  
JANUARY 11, 2016

GTU RELOCATION PROJECT  
TERMINAL 1 REDEVELOPMENT PROGRAM  
SAN FRANCISCO INTERNATIONAL AIRPORT

PAULETT TAGGART  
ARCHITECTS



- CMU BLOCK WALL, SSD
- GSM COUNTER FLASHING W/ SAWCUT  
REGLET SET IN SEALANT
- IMBED BOLTS , SSD
- GSM FURRING CHANNEL 16" o.c.
- 20 G.A. GALV GSM PANEL PAINT
- S.S. FASTENER WITH OVERSIZE HOLE  
FOR MOVEMENT
- 6" STEEL STUD
- C 8 X 13.7 STEEL FRAME (4 SIDES) PAINT
- 8 mm FIBER CEMENT PANEL ATTACH W/  
S.S. RIVETS PER MFR'S INSTRUCTIONS

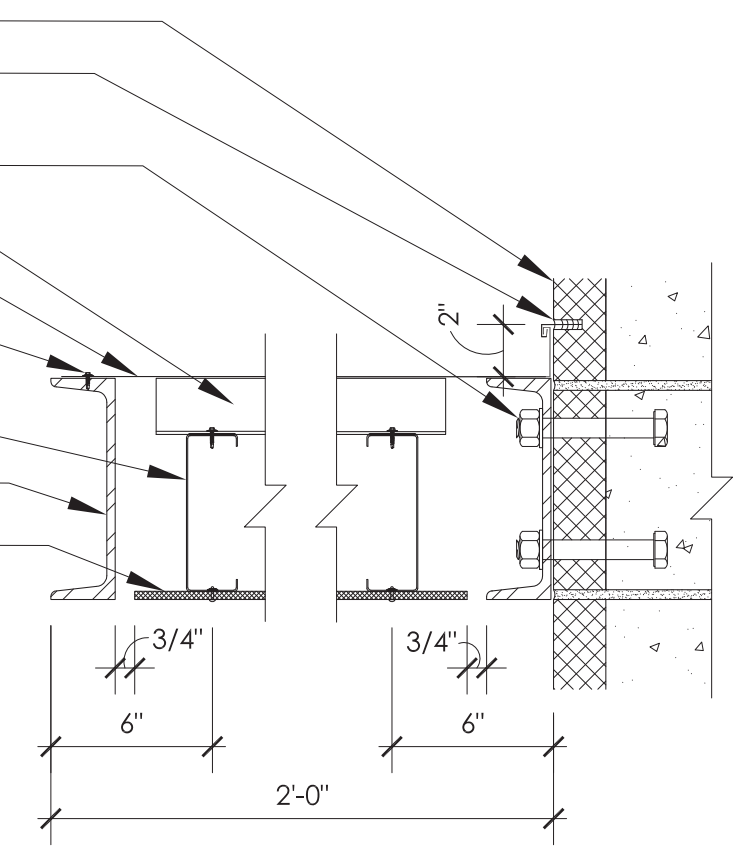

CANOPY DETAIL SECTION B

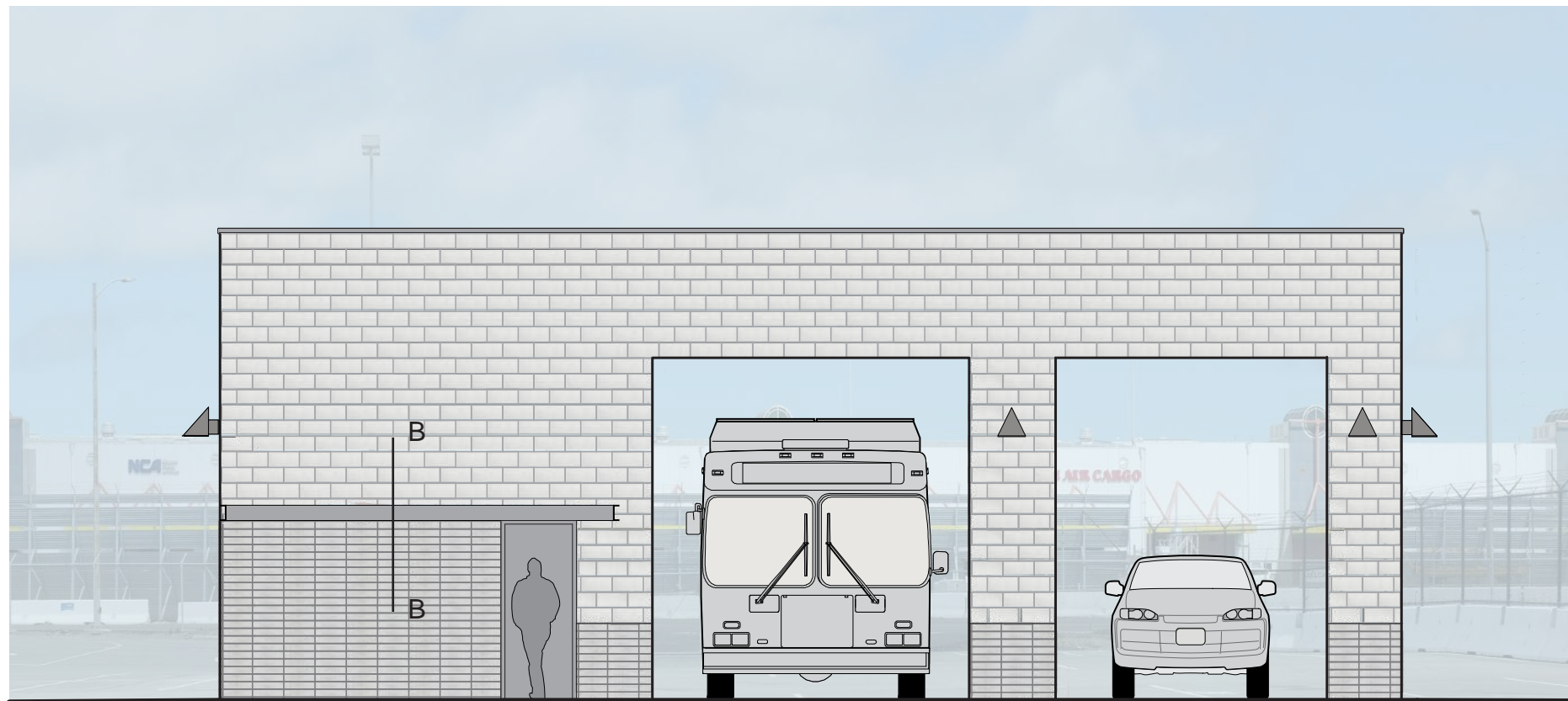

GTU RELOCATION PROJECT  
 TERMINAL 1 REDEVELOPMENT PROGRAM  
 SAN FRANCISCO INTERNATIONAL AIRPORT



mwa architects



CIVIC DESIGN PRESENTATION: PHASE 2 DESIGN DEVELOPMENT & PHASE 3 CONSTRUCTION DOCUMENTS  
 JANUARY 11, 2016

PAULETT TAGGART  
 ARCHITECTS



mwa architects



CIVIC DESIGN PRESENTATION: PHASE 2 DESIGN DEVELOPMENT & PHASE 3 CONSTRUCTION DOCUMENTS  
JANUARY 11, 2016 REVISED JANUARY 25, 2016

GTU RELOCATION PROJECT  
TERMINAL 1 REDEVELOPMENT PROGRAM  
SAN FRANCISCO INTERNATIONAL AIRPORT

PAULETT TAGGART  
ARCHITECTS





mwa architects



CIVIC DESIGN PRESENTATION: PHASE I SCHEMATIC DESIGN  
DECEMBER 14, 2015

GTU RELOCATION PROJECT  
TERMINAL 1 REDEVELOPMENT PROGRAM  
SAN FRANCISCO INTERNATIONAL AIRPORT

PAULETT TAGGART  
ARCHITECTS



mwa architects



CIVIC DESIGN PRESENTATION: PHASE 2 DESIGN DEVELOPMENT & PHASE 3 CONSTRUCTION DOCUMENTS  
JANUARY 25, 2016

GTU RELOCATION PROJECT  
TERMINAL 1 REDEVELOPMENT PROGRAM  
SAN FRANCISCO INTERNATIONAL AIRPORT

PAULETT TAGGART  
ARCHITECTS



mwa architects



CIVIC DESIGN PRESENTATION: PHASE 2 DESIGN DEVELOPMENT & PHASE 3 CONSTRUCTION DOCUMENTS  
JANUARY 25, 2016

GTU RELOCATION PROJECT  
TERMINAL 1 REDEVELOPMENT PROGRAM  
SAN FRANCISCO INTERNATIONAL AIRPORT

PAULETT TAGGART  
ARCHITECTS