

LEAH ROSENBERG SFO MURAL - Structural Renderings

Artwork: Painted 3/4" strips of Pre-primed pine engineered lumber
Strips @ 2", 3.25", and 5.25" thickness
Accents of powder-coated aluminum, acrylic mirror adhered to wood

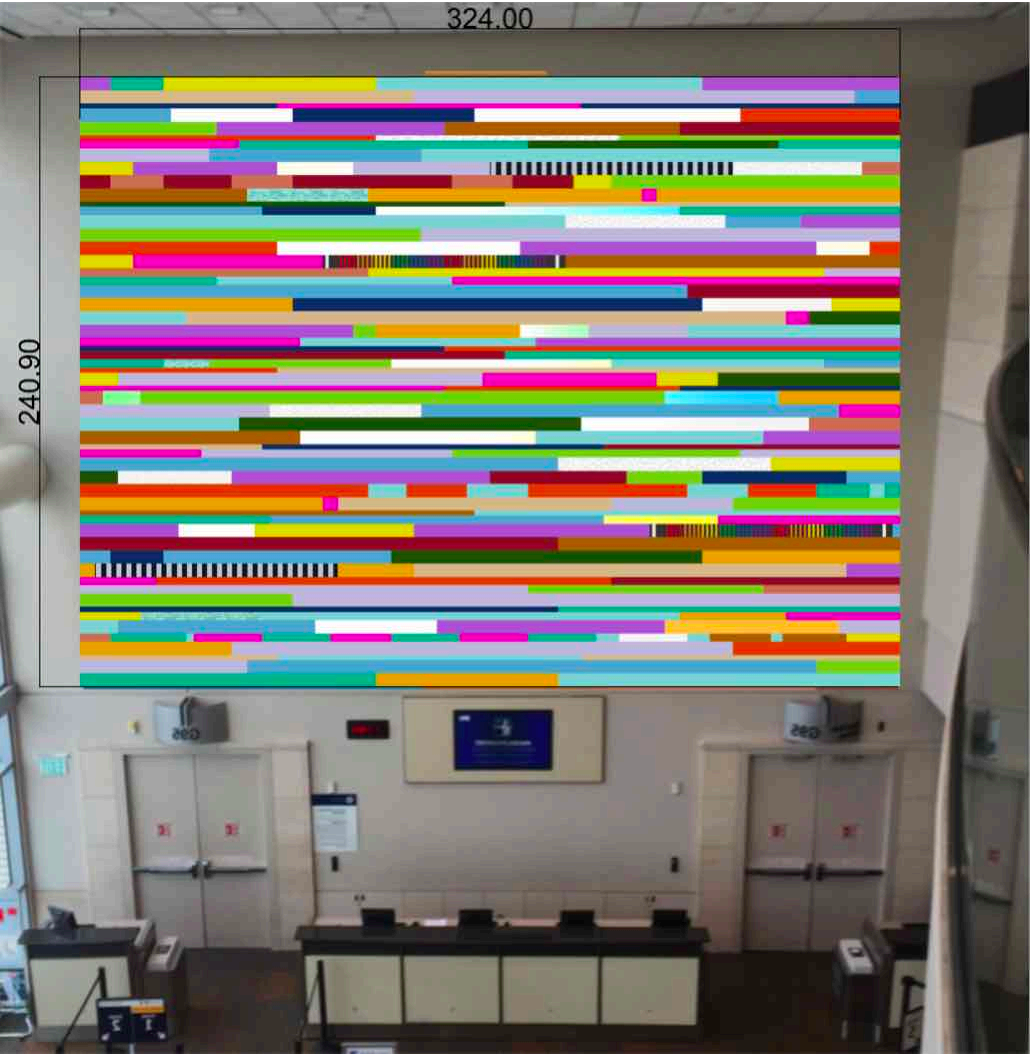

ONE HAT ONE HAND
1335 YOSEMITE AVE.
SAN FRANCISCO, CA
94124



ASSOCIATE
Benjamin Turner
415-822-2020 X120
ben@onehatonehand.com

ASSOCIATE 2
415-822-2020
info@onehatonehand.com

CLIENT
Leah Rosenberg
SFAC

PROJECT
SFO Mural

PROJECT #
9076

DRAWN BY
BT

ISSUE
06.15.2017

RE-ISSUE



A0.1

LEAH ROSENBERG SFO MURAL - Structural Renderings

Artwork Dimensions: 324" W x 241" H x 2-3/4" D
 Artwork mounted onto 3/4" ply mounting layer + cleats
 Artwork cleats mount with 3/4" ply wall cleats

ONE HAT ONE HAND
 1335 YOSEMITE AVE.
 SAN FRANCISCO, CA
 94124

PLAN VIEW

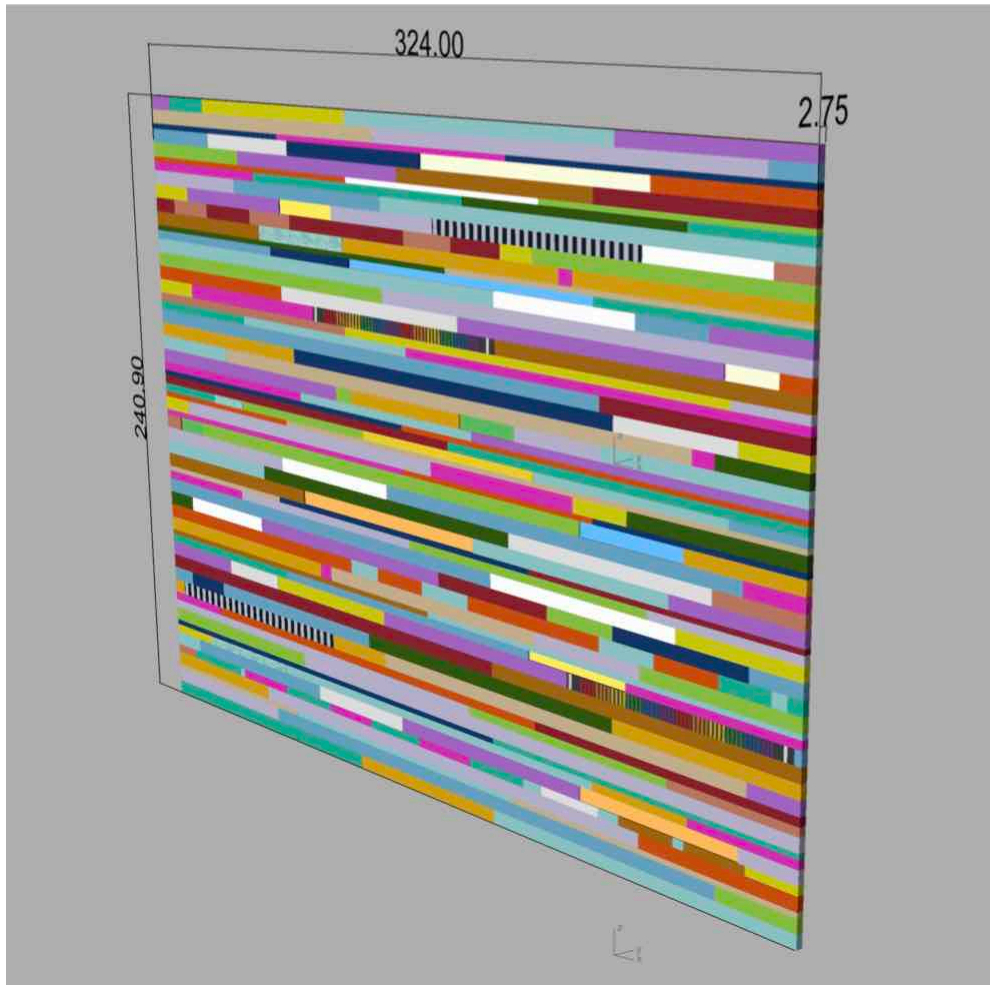

2.75" return
 painted wood
 to hide cleat system



3/4" birch ply
 cleat mounted
 to airport wall

Artwork mounting
 layer 2" (3/4" ply
 + 1-1/4" cleat)

Front artwork
 thickness

1/2" scab between
 horizontal ply
 sections

ASSOCIATE
 Benjamin Turner
 415-822-2020 X120
 ben@onehatonehand.com

ASSOCIATE 2
 415-822-2020
 info@onehatonehand.com

CLIENT
 Leah Rosenberg
 SFAC

PROJECT
 SFO Mural

PROJECT #
 9076

DRAWN BY
 BT

ISSUE
 06.15.2017

RE-ISSUE



A_{0.2}

LEAH ROSENBERG SFO MURAL - Structural Renderings

Artwork Mounting: Fasteners

WALL CLEAT: Mount 3/4" plywood wall cleat to 2x6 x1/4" steel airport studs

Wood to Steel Simpson Strong-Tie Screws: https://www.strongtie.com/strongdrive_metalscrews/tb_screw/p/strong-drive-tb-wood-to-steel-screw

Screw Pattern: 16" OC horizontal ; 24" OC vertical (Minimum 12 per panel or 72 total)

ONE HAT ONE HAND
1335 YOSEMITE AVE.
SAN FRANCISCO, CA
94124

ASSOCIATE
Benjamin Turner
415-822-2020 X120
ben@onehatonehand.com

ASSOCIATE 2
415-822-2020
info@onehatonehand.com

CLIENT
Leah Rosenberg
SFAC

PROJECT
SFO Mural

PROJECT #
9076

DRAWN BY
BT

ISSUE
06.15.2017

RE-ISSUE

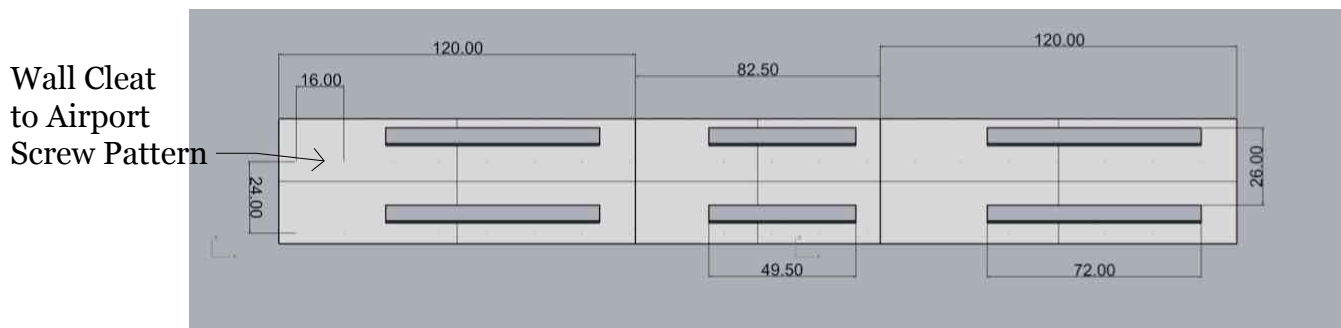
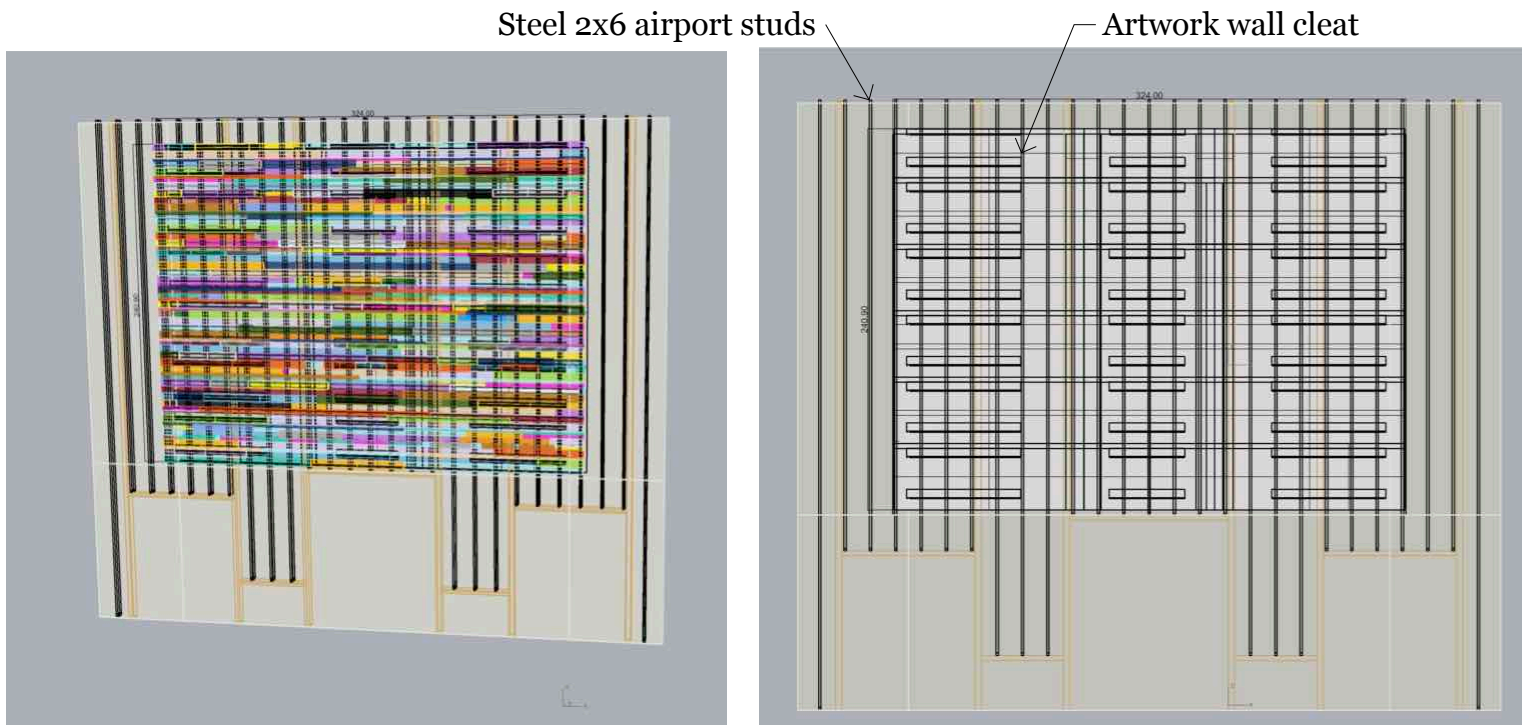
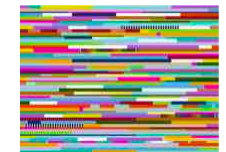

A0.3

LEAH ROSENBERG SFO MURAL - Structural Renderings

Cleat Detail: Layer Renderings

Mural installs in (6) stacked 324" x 42" horizontal sections

ONE HAT ONE HAND
1335 YOSEMITE AVE.
SAN FRANCISCO, CA
94124

ASSOCIATE
Benjamin Turner
415-822-2020 X120
ben@onehatonehand.com

ASSOCIATE 2
415-822-2020
info@onehatonehand.com

CLIENT
Leah Rosenberg
SFAC

PROJECT
SFO Mural

PROJECT #
9076

DRAWN BY
BT

ISSUE
06.15.2017

RE-ISSUE

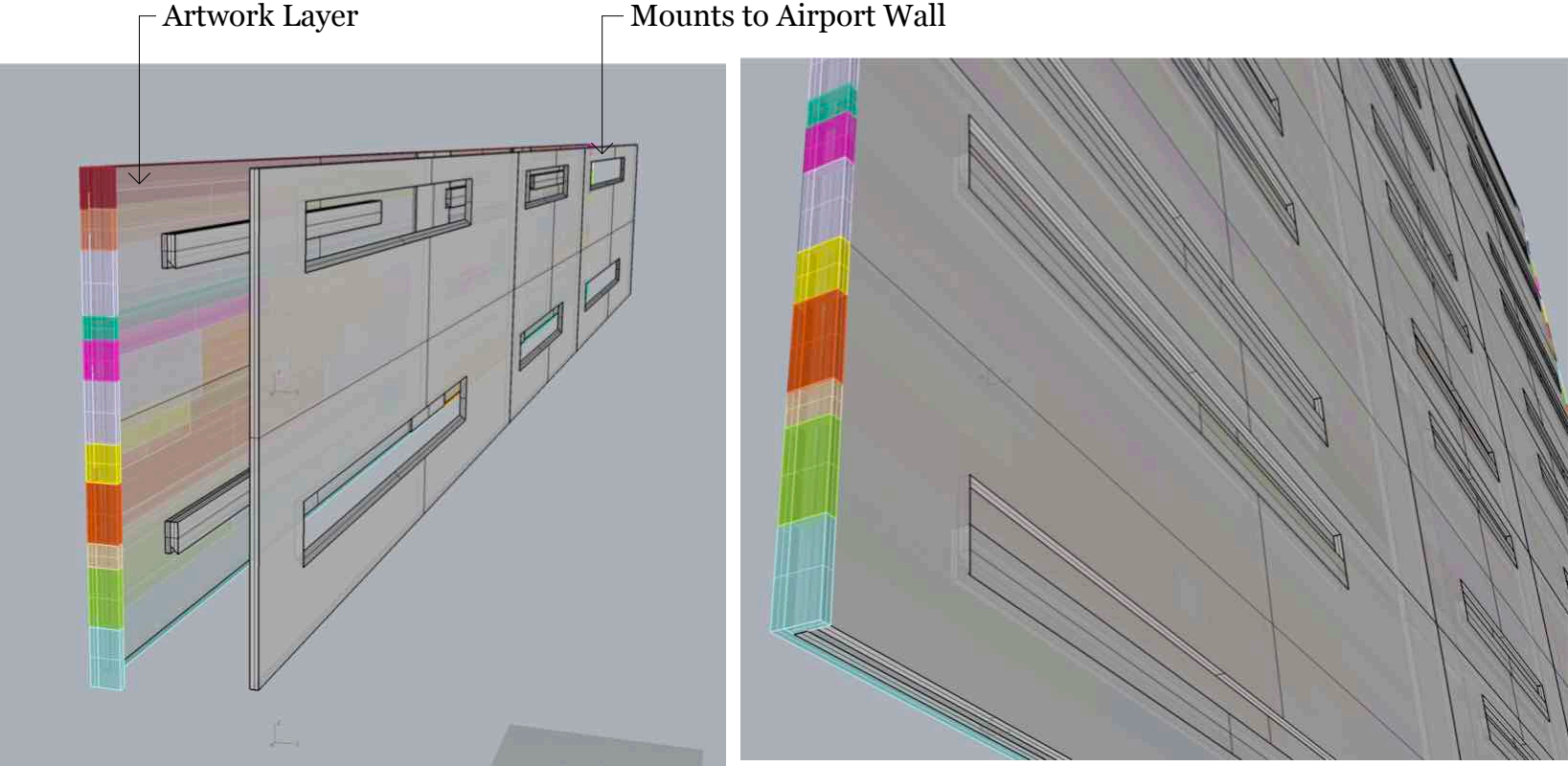

A_{0.4}

LEAH ROSENBERG SFO MURAL - Structural Renderings

Cleat Detail: Layer Dimensions: Mural installs in (6) stacked 324" x 42" horizontal sections

ONE HAT ONE HAND
1335 YOSEMITE AVE.
SAN FRANCISCO, CA
94124

ASSOCIATE
Benjamin Turner
415-822-2020 X120
ben@onehatonehand.com

ASSOCIATE 2
415-822-2020
info@onehatonehand.com

CLIENT
Leah Rosenberg
SFAC

PROJECT
SFO Mural

PROJECT #
9076

DRAWN BY
BT

ISSUE
06.15.2017

RE-ISSUE



A_{0.5}

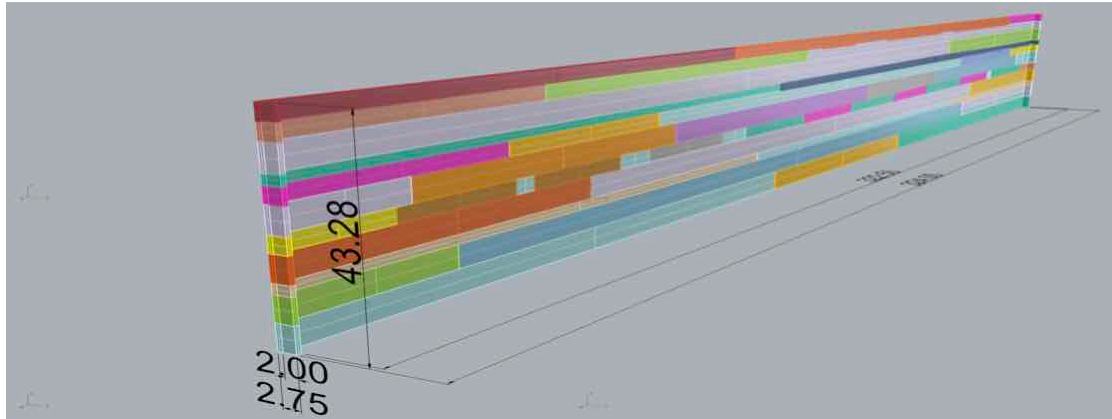

Artwork

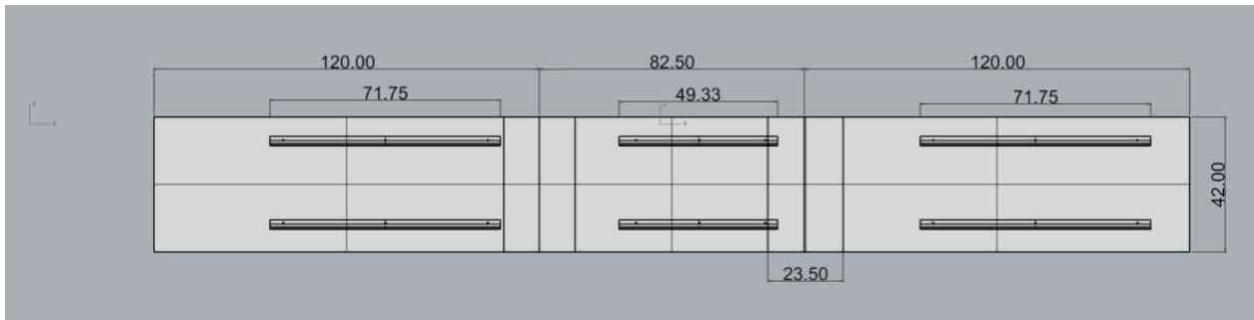

Artwork
Backing
Panel
w/ male
cleats

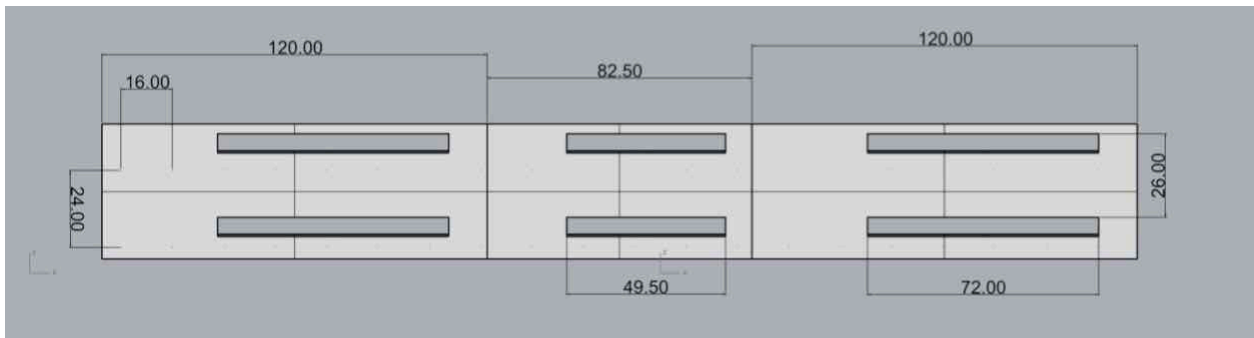

Wall
Mount
Cleats

LEAH ROSENBERG SFO MURAL - Structural Renderings

Cleat Detail: Fasteners

ARTWORK CLEATS TO ARTWORK BACKING LAYER:

1/4-20 Hex bolts for cleats: ASTM A307

Bolt Pattern: 3 bolts per 6' cleat (+ Titebond II wood glue for additional adhesion)

ONE HAT ONE HAND
1335 YOSEMITE AVE.
SAN FRANCISCO, CA
94124

ASSOCIATE
Benjamin Turner
415-822-2020 X120
ben@onehatonehand.com

ASSOCIATE 2
415-822-2020
info@onehatonehand.com

CLIENT
Leah Rosenberg
SFAC

PROJECT
SFO Mural

PROJECT #
9076

DRAWN BY
BT

ISSUE
06.15.2017

RE-ISSUE

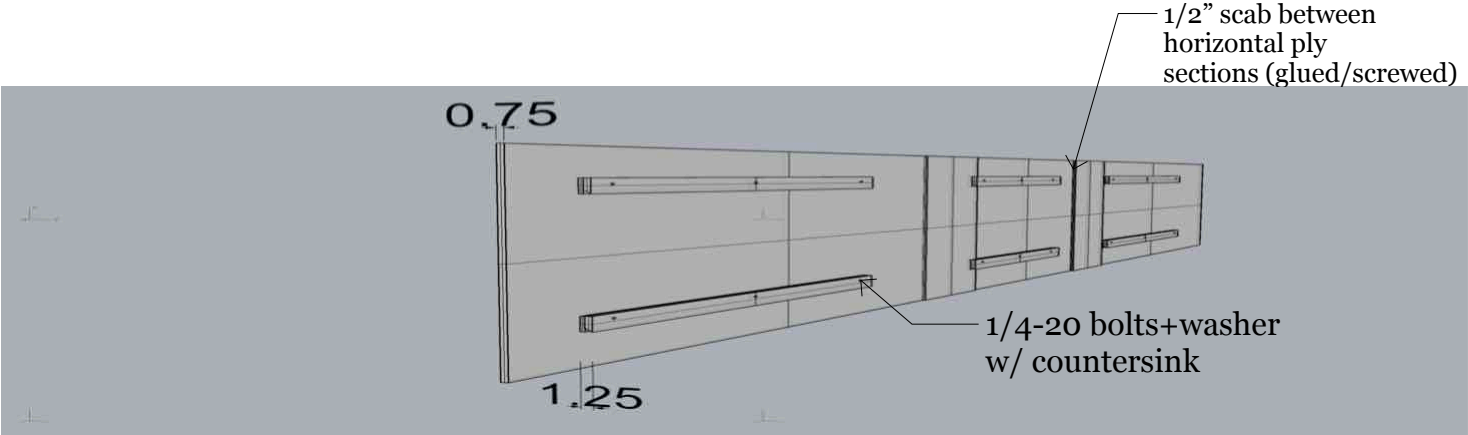
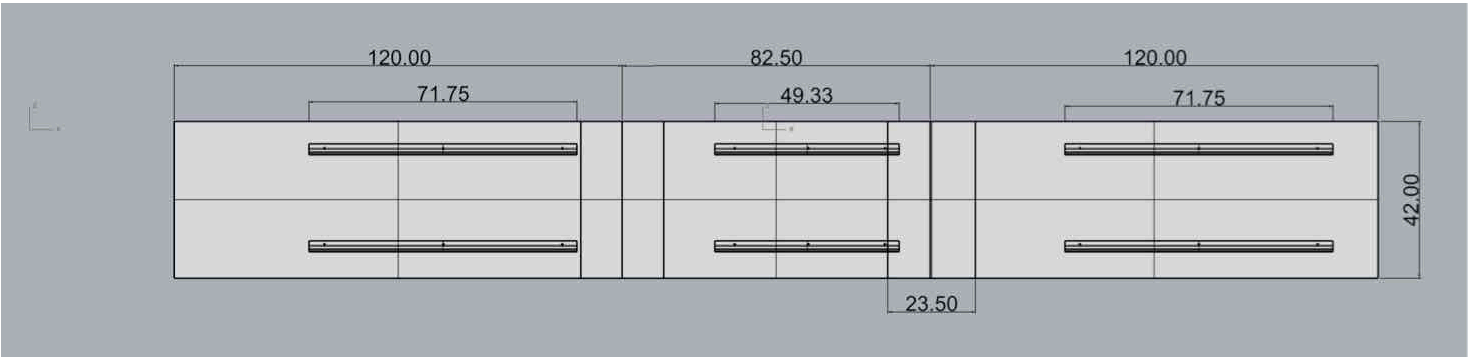

A_{0.6}

LEAH ROSENBERG SFO MURAL - Structural Renderings

Artwork Materials: Painted 3/4" strips of Pre-primed pine engineered lumber
Strips @ 2", 3.25", and 5.25" thickness
Accents of powder-coated aluminum, acrylic mirror adhered to wood
All artwork layers glued and back-screwed to 3/4" ply backing layer

ONE HAT ONE HAND
1335 YOSEMITE AVE.
SAN FRANCISCO, CA
94124

ASSOCIATE
Benjamin Turner
415-822-2020 X120
ben@onehatonehand.com

ASSOCIATE 2
415-822-2020
info@onehatonehand.com

CLIENT
Leah Rosenberg
SFAC

PROJECT
SFO Mural

PROJECT #
9076

DRAWN BY
BT

ISSUE
06.15.2017

RE-ISSUE

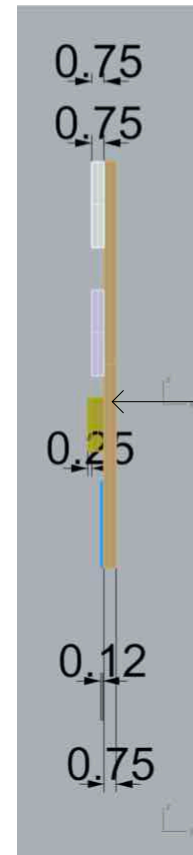

A_{0.7}

EVERYWHERE A COLOR

INTERNATIONAL ORANGE/GOLDEN GATE BRIDGE

FOG ON TWIN PEAKS

PALM TREES AT CRISSY FIELDS

PAINTED LADIES IN THE WESTERN ADDITION

TURQUOISE STREET CAR ON MARKET STREET

THE DUTCH WINDMILL BY THE OCEAN

CLAES OLDENBURG "CUPID'S SPAN" ON THE EMBARACADERO

CROSS THE WALK IN THE CASTRO

SF MOMA STRIATED TURRET

BUFFALO IN GOLDEN GATE PARK

BRIGHT GREEN PARROTS OF TELEGRAPH HILL

SPARKLY FOR THE BAY LIGHTS

TORTILLAS IN THE MISSION

BLUE SKIES ACROSS THE BAY

DRY FARM TOMATOES AT THE FARMER'S MARKET

CALIFORNIA POPPIES

THE GREEN DRAGON THE GATE IN CHINATOWN

NEON ORANGE TOSCA SIGN IN NORTH BEACH