

SFO Interim Boarding Area B

Civic Design Review (Phase 3)
July 20, 2015

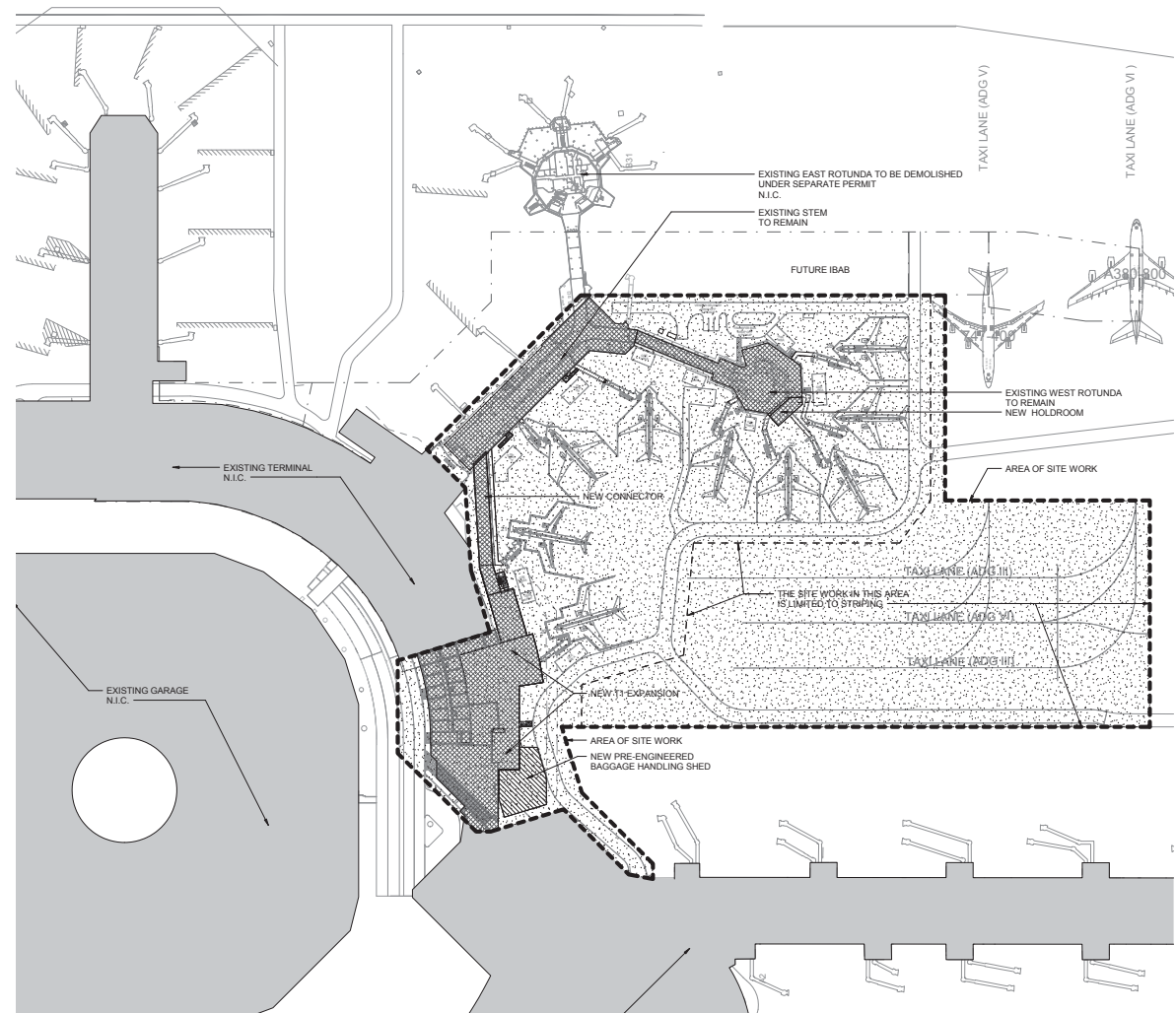

Site Plan

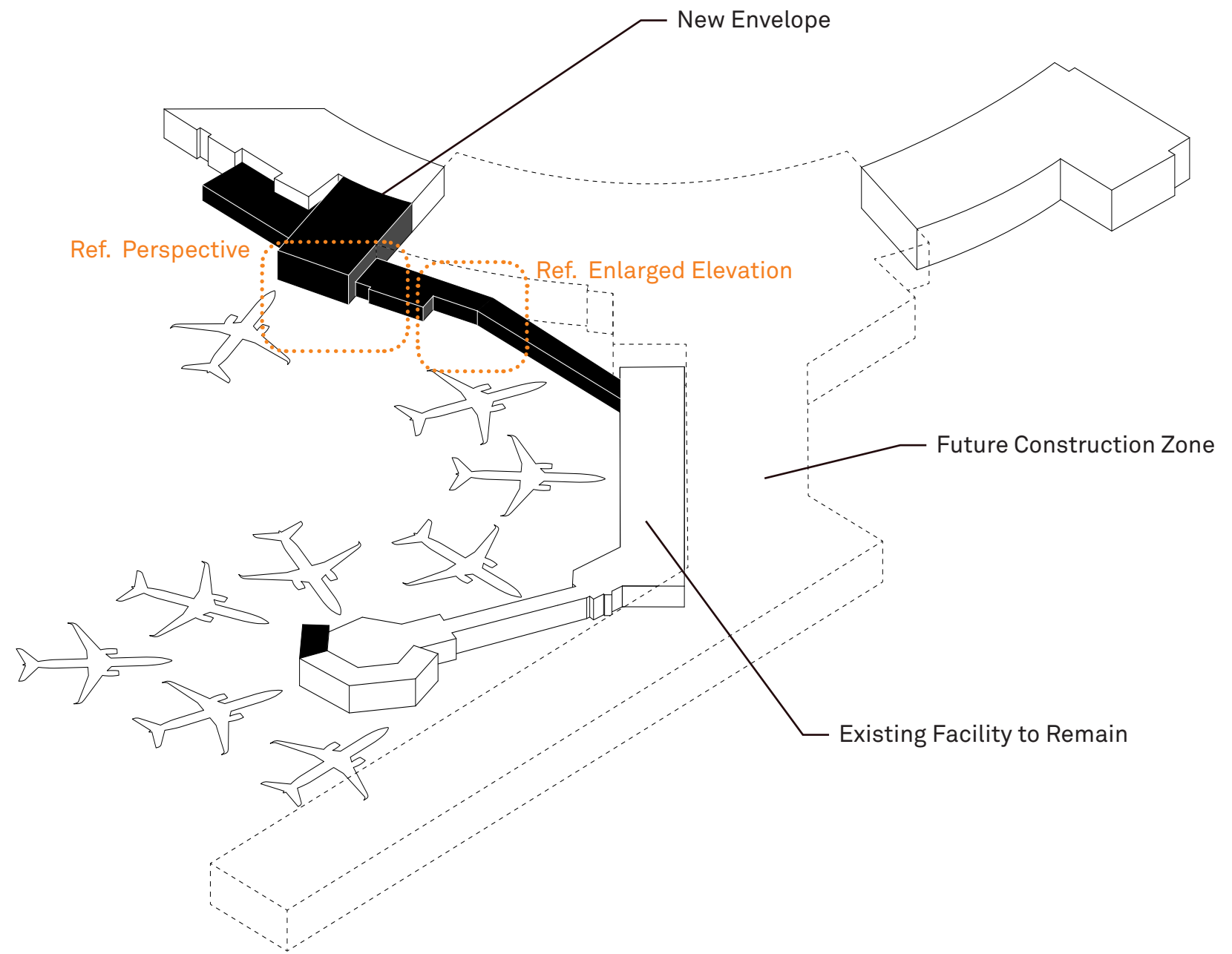

New/Existing Construction Diagram



Exterior Perspective (Highlighting Panel Cladding Details and Window Trim) nts

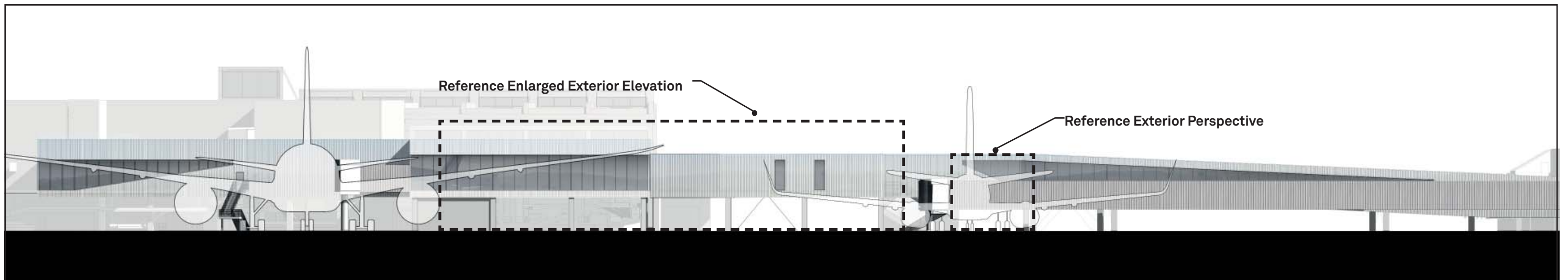

Exterior Elevation nts

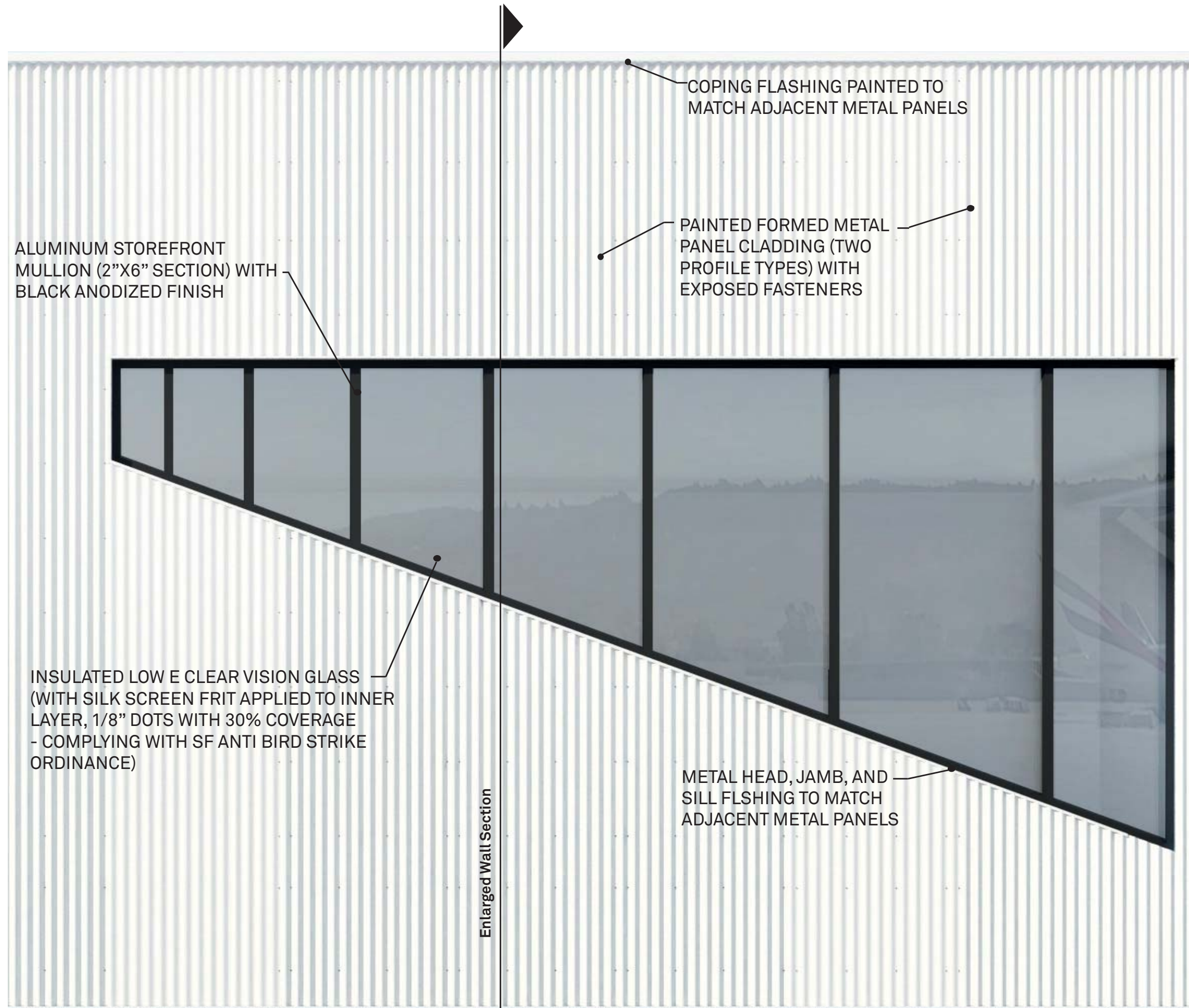

Enlarged Exterior Elevation at New Connector Bridge nts

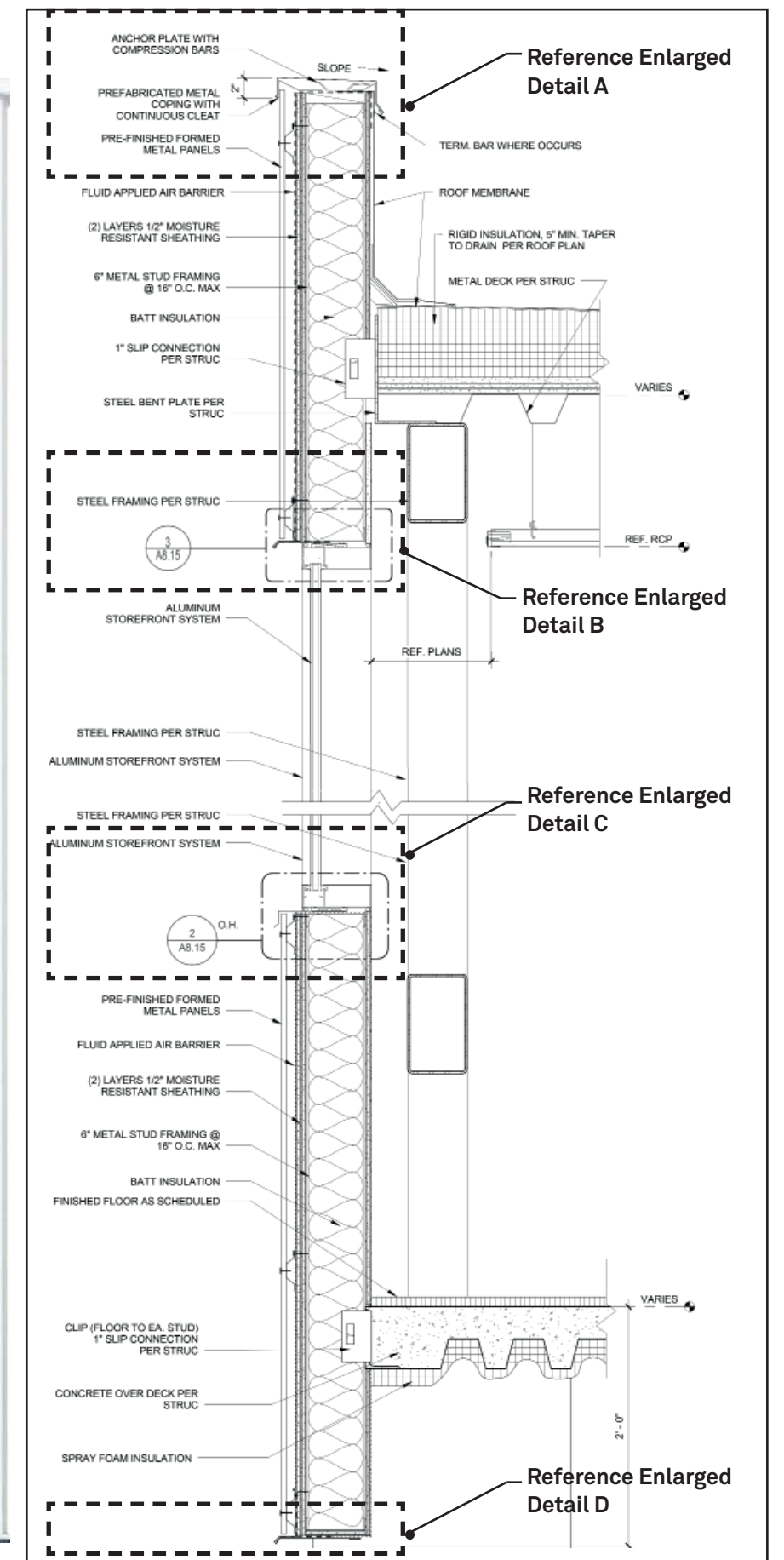

Enlarged Exterior Wall Section at New Connector Bridge nts

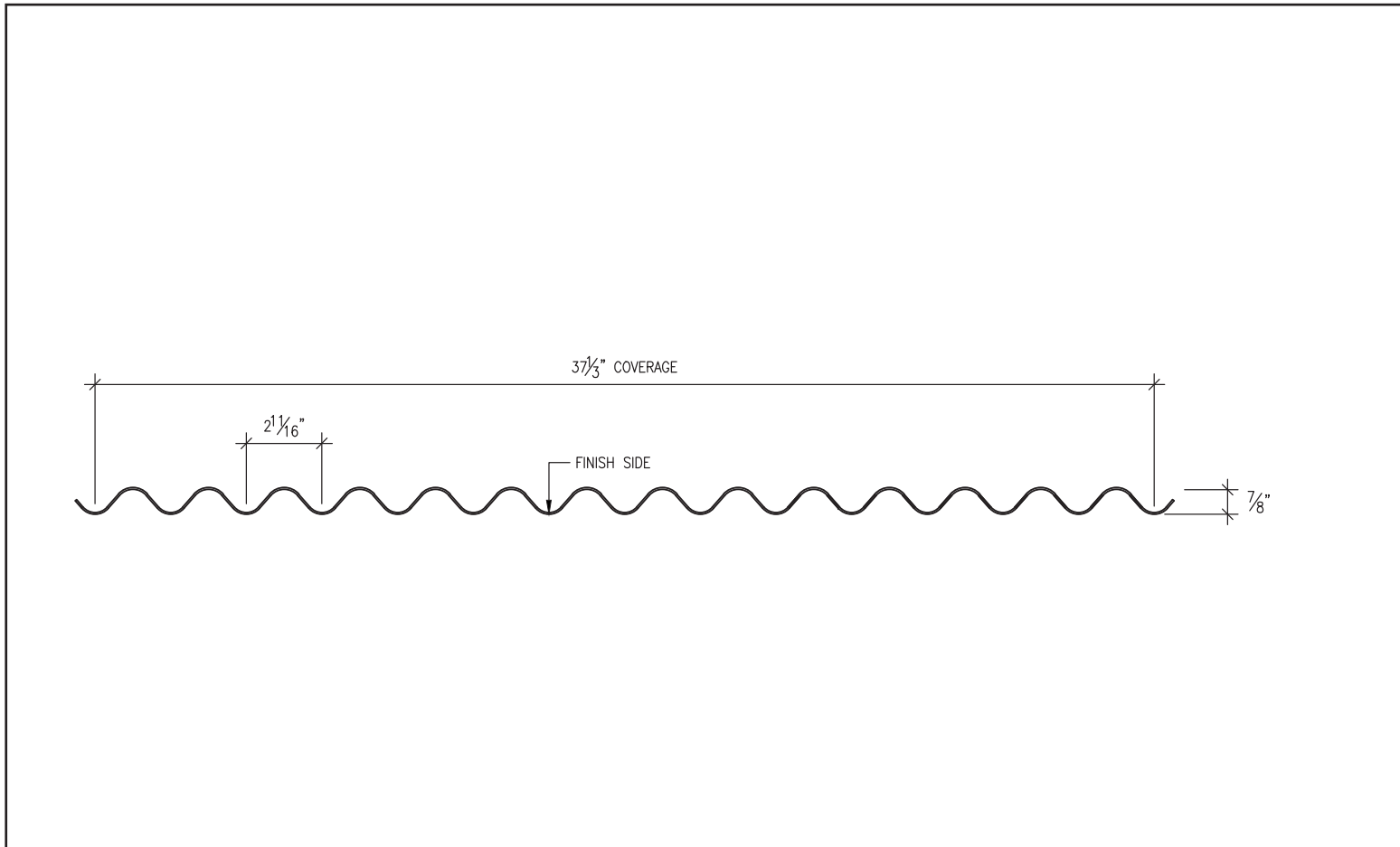

Profile Section of Formed Metal Panel - Pattern A nts

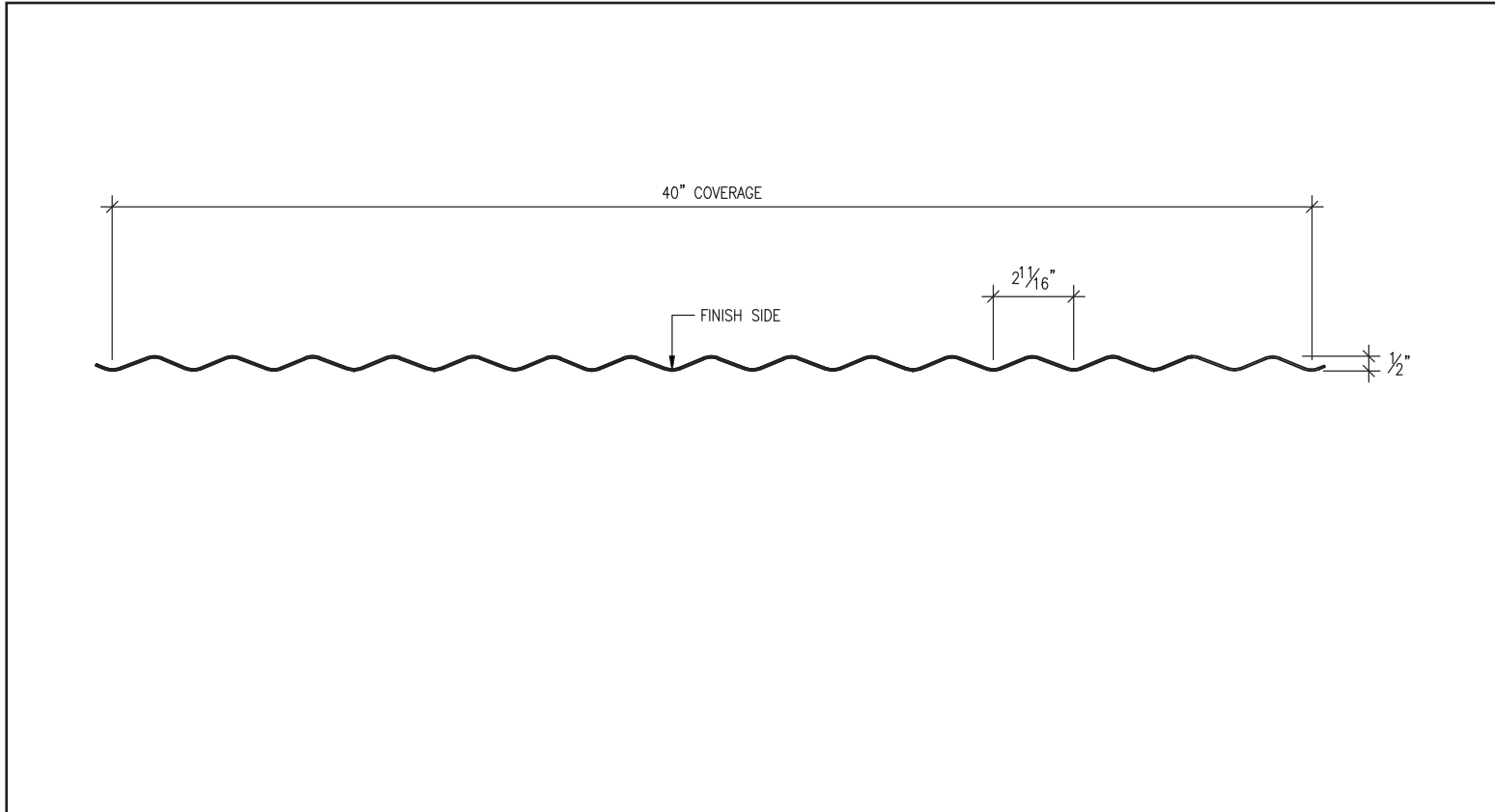

Profile Section of Formed Metal Panel - Pattern B nts

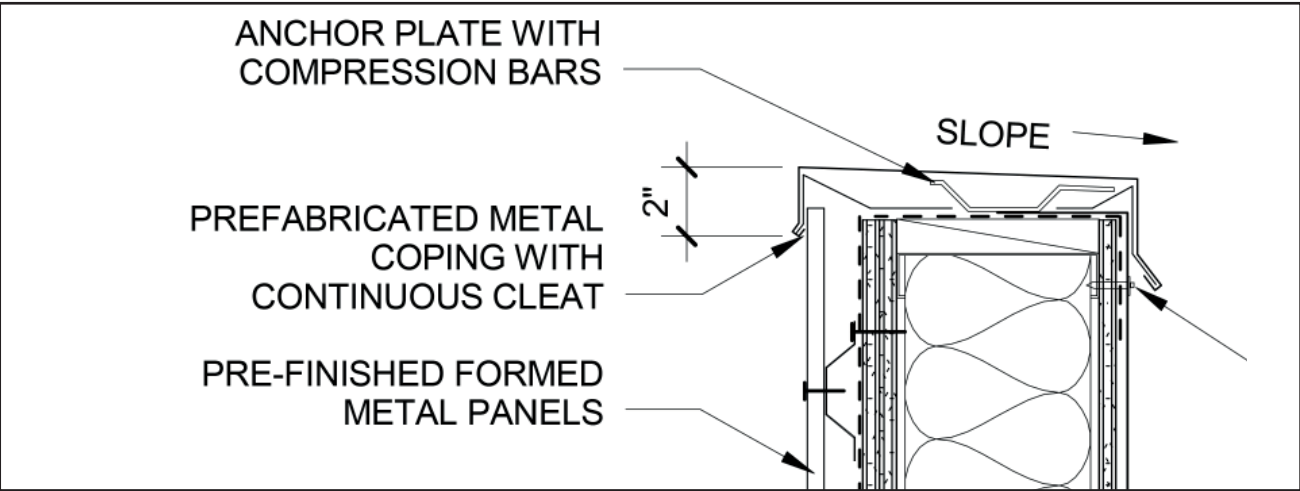

Enlarged Detail A at Exterior Wall Parapet nts

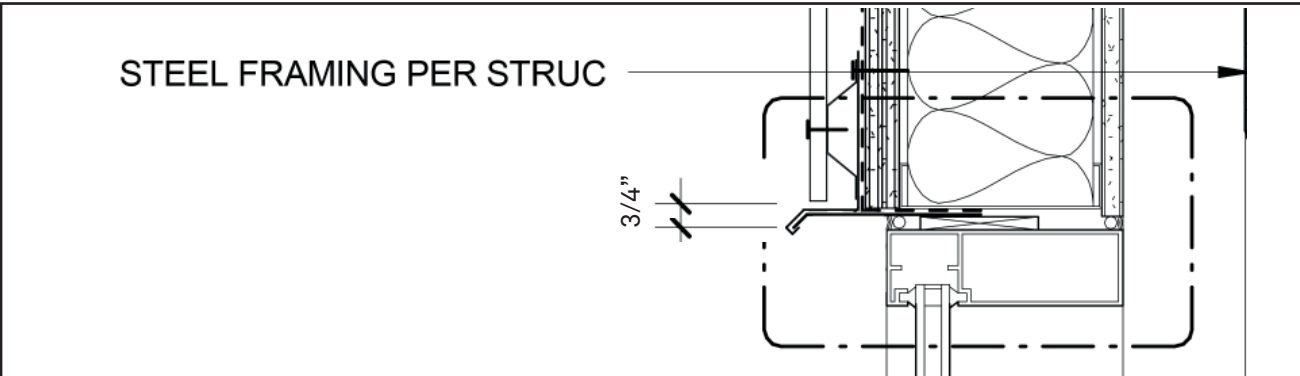

Enlarged Detail B at Exterior Window Head nts

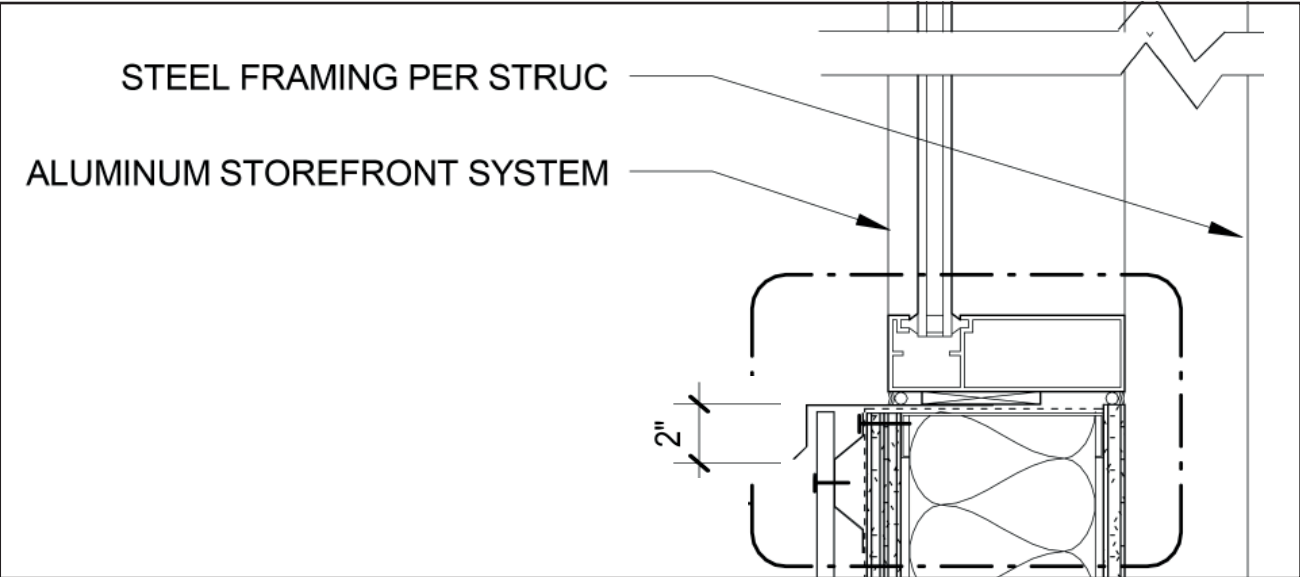

Enlarged Detail C at Exterior Window Sill nts

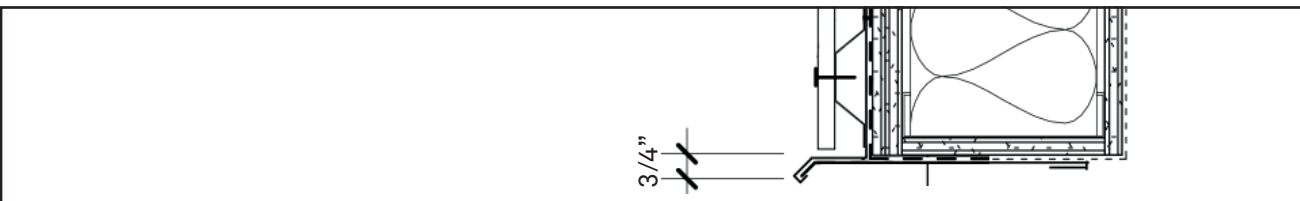

Enlarged Detail D at Exterior Wall Base nts