

UTILITY ENCLOSURES

TREASURE ISLAND AND YERBA BUENA ISLAND

PHASE 3 - DESIGN REVIEW

SAN FRANCISCO ARTS COMMISSION



TI / YBI PUMP STATIONS - LOCATIONS



● HIGHER PRIORITY FACILITY
⦿ FUTURE PHASE FACILITY

○ LOWER PRIORITY FACILITY

TI / YBI PUMP STATIONS

YBI - MACALLA ROAD

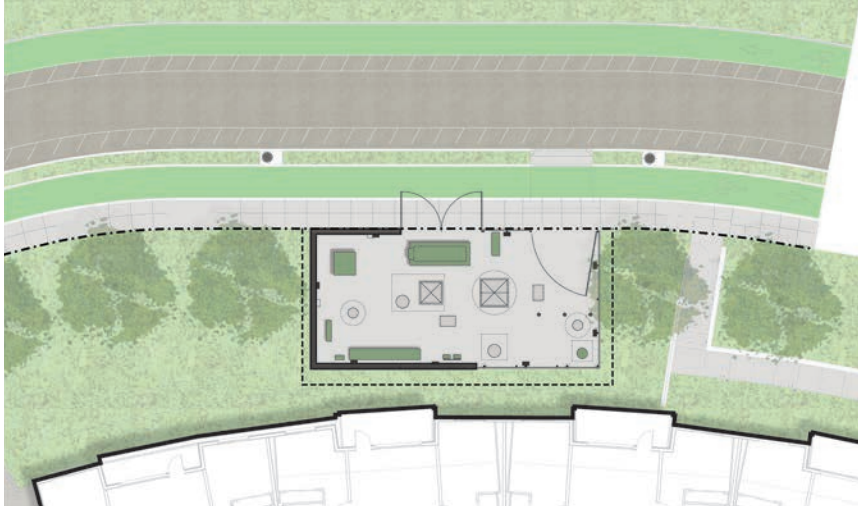

YBI - NORTHGATE



TI - 5TH STREET

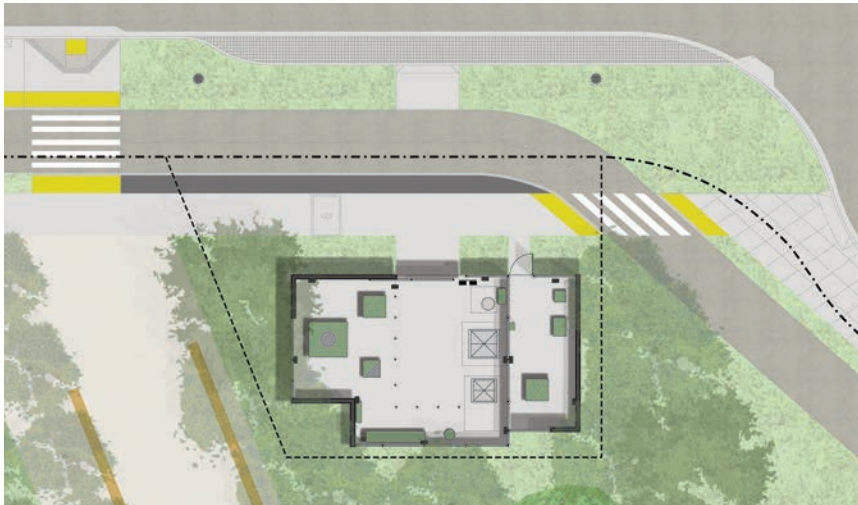

TI - 4TH STREET

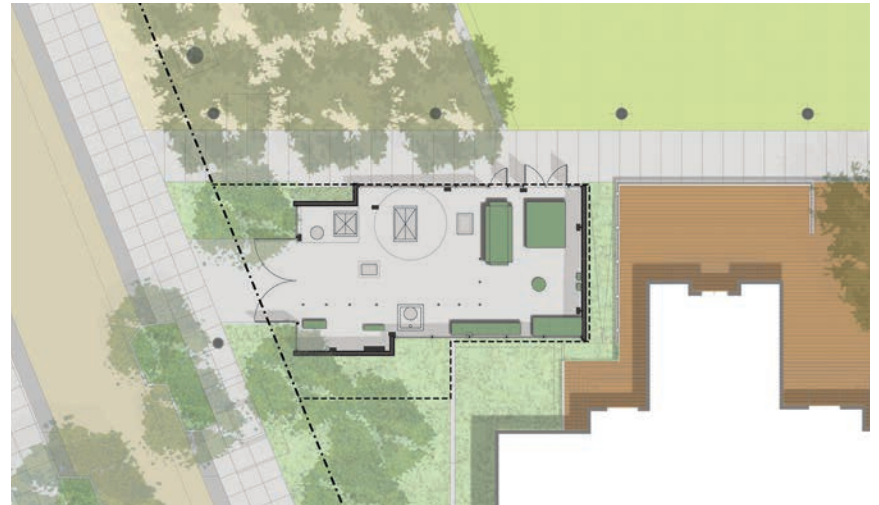

PROPOSED MATERIAL PALETTE

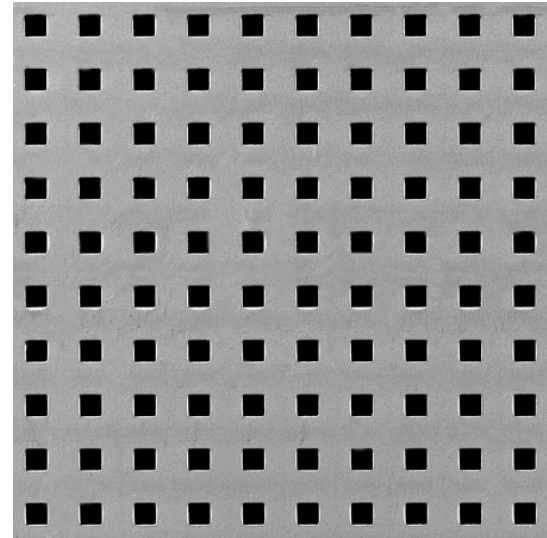

TI / YBI PUMP STATIONS

PHASE 3 - DESIGN CHANGES AND CONTIGENCIES

1. ALL PUMP STATIONS

METAL PANEL MATERIAL CHANGE - PERFORATION SIZE AND SPACING CHANGE

2. TI - 4TH STREET

MINOR CHANGE TO ENCLOSURE LAYOUT

3. TI - 4TH STREET AND 5TH STREET

PHASE 2 CONTIGENCY - STUDY VERTICAL SPACING OF POSTS TO BE MORE EQUAL

TI / YBI PUMP STATIONS

METAL PANEL MATERIAL

PREVIOUS MATERIAL AND PERFORATION SIZE :
PAINTED ALUMINUM
1/4" PERFORATIONS AT 1/2" OC
25% TRANSPARENCY

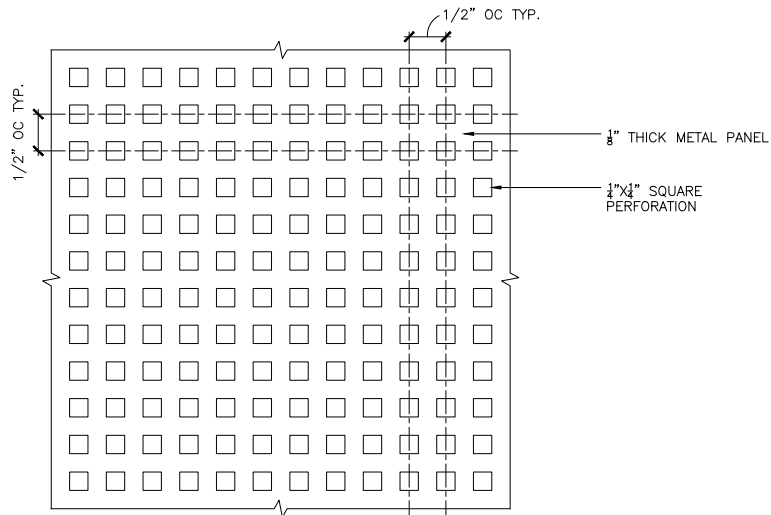

CURRENT MATERIAL AND PERFORATION SIZE :
PAINTED STAINLESS STEEL
1/2" PERFORATIONS AT 1 3/8" OC
13% TRANSPARENCY

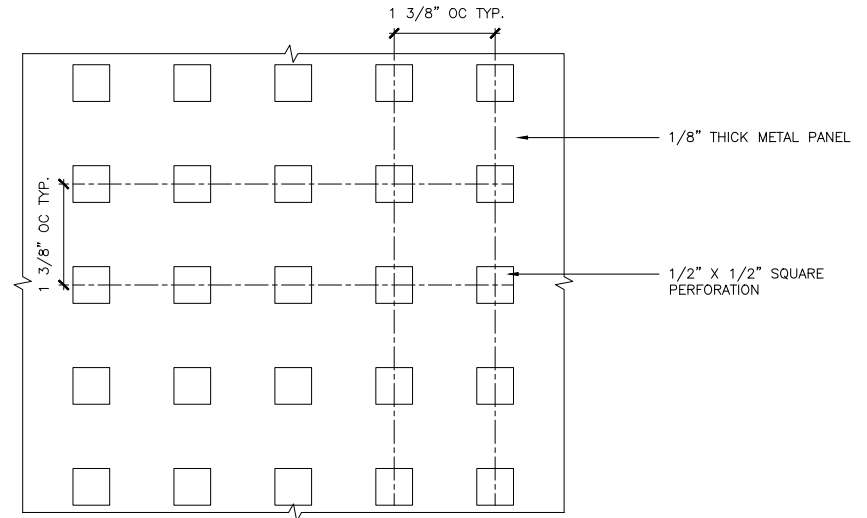

4TH STREET PUMP STATION CULTURAL PARK

PREVIOUS PROPOSED PLAN

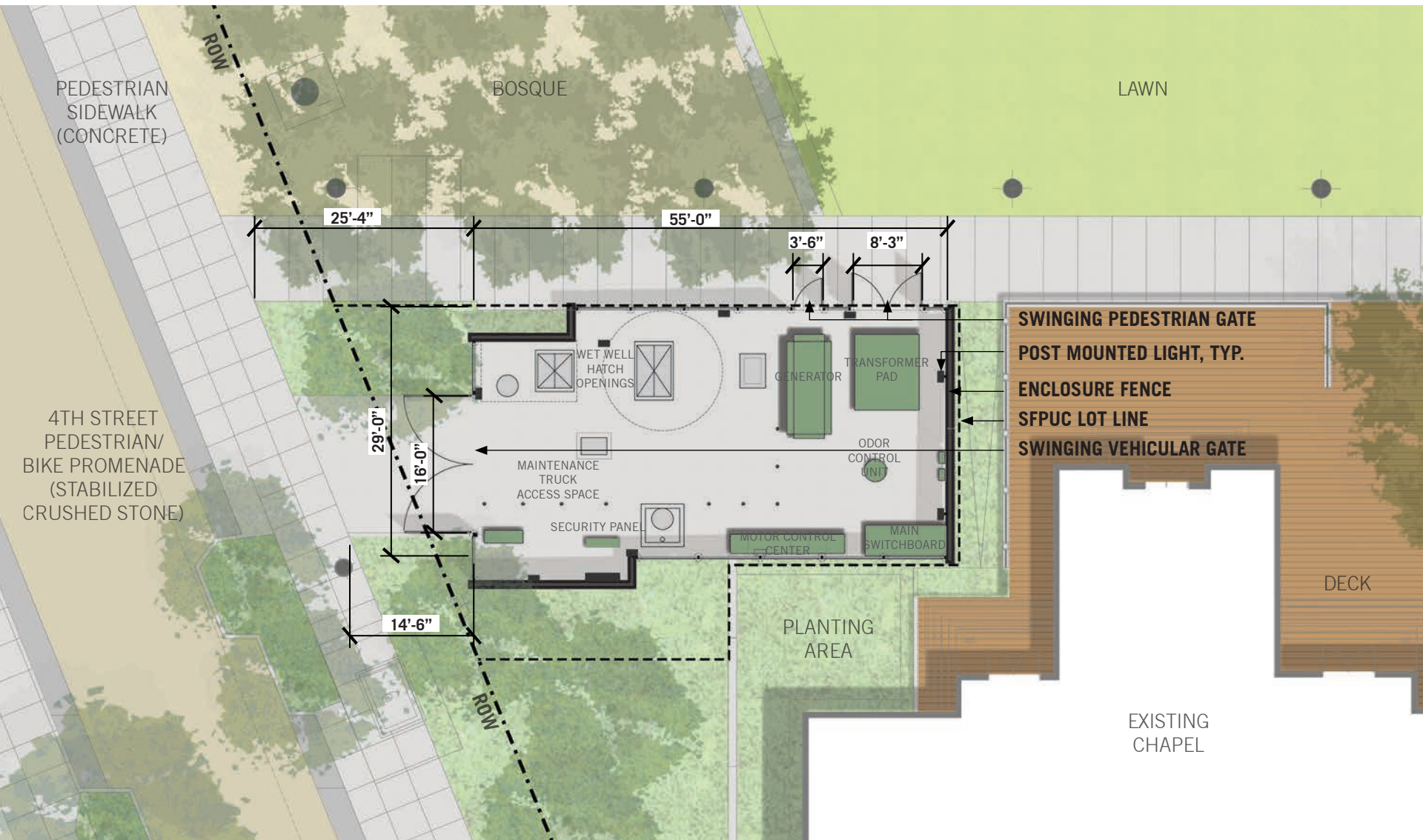

- SWINGING PEDESTRIAN GATE
- POST MOUNTED LIGHT, TYP.
- ENCLOSURE FENCE
- SFPUC LOT LINE
- SWINGING VEHICULAR GATE

4TH STREET PUMP STATION CULTURAL PARK

CURRENT PROPOSED PLAN

LAYOUT ADJUSTED AT
NORTHEAST CORNER
TO ACCOMODATE
VAULT CLEARANCE
REQUIREMENTS

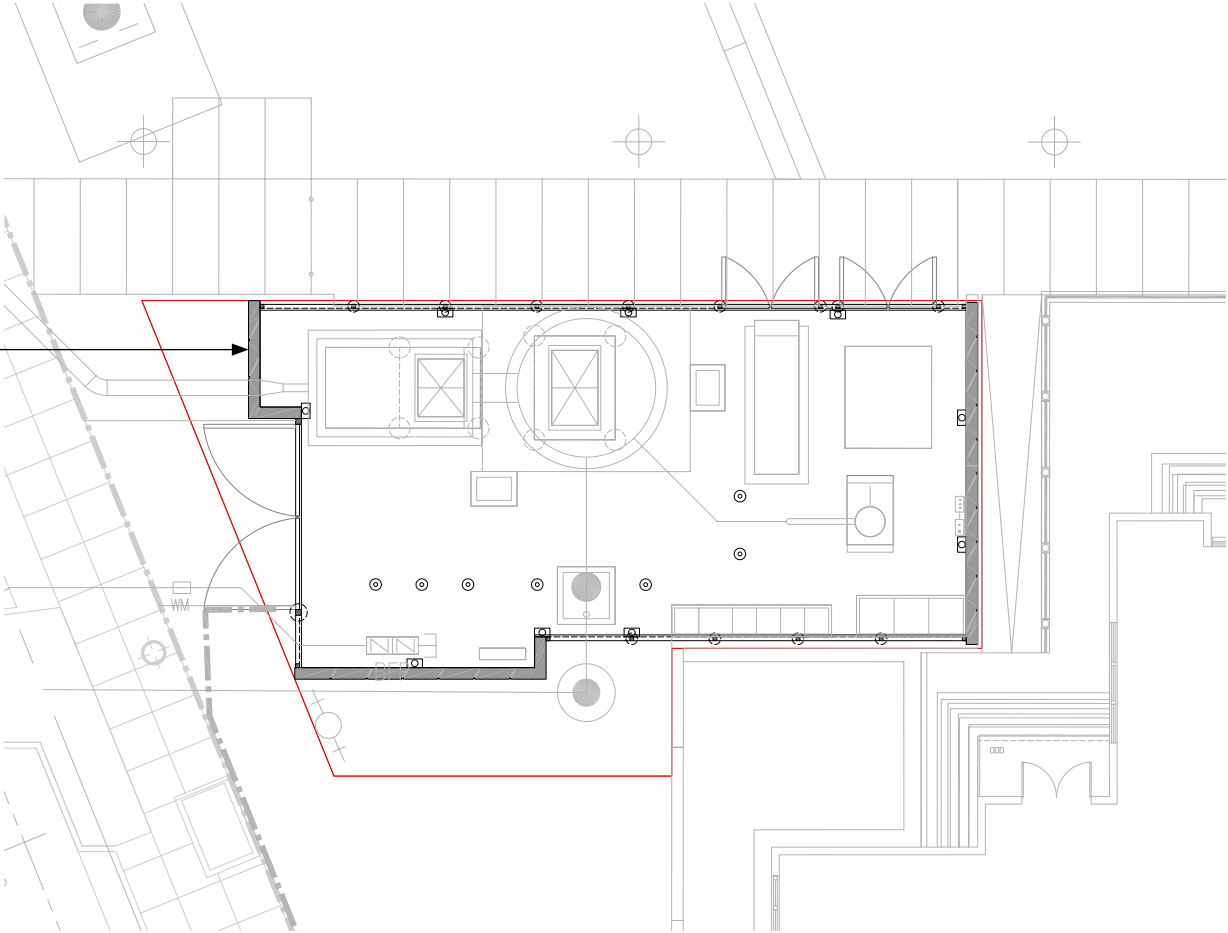

4TH STREET PUMP STATION CULTURAL PARK

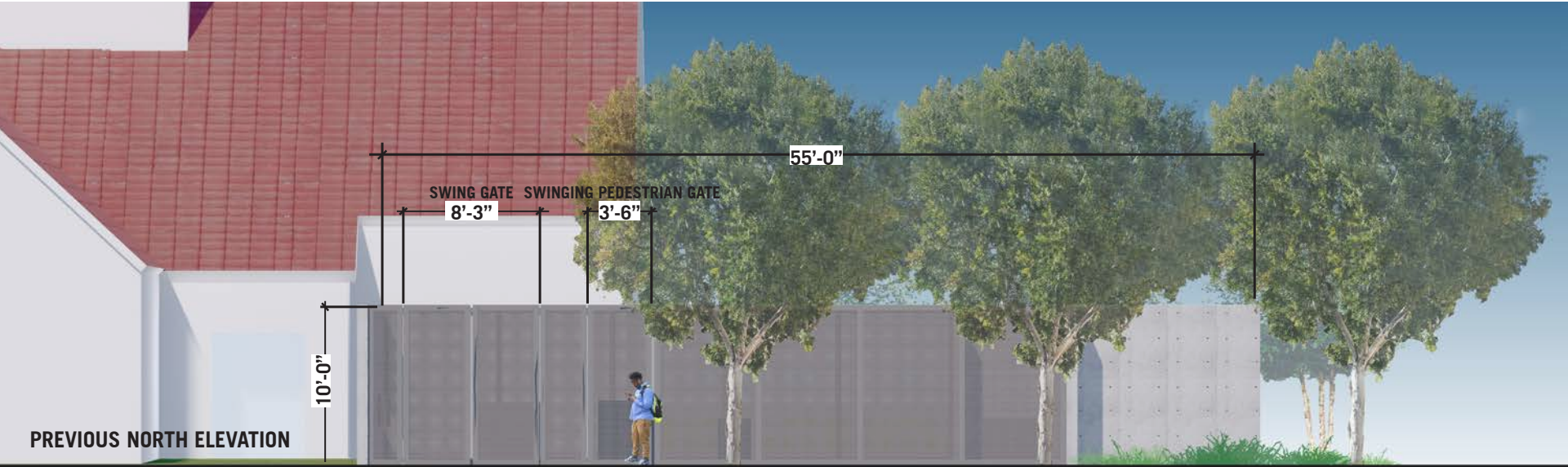

PREVIOUS NORTH ELEVATION

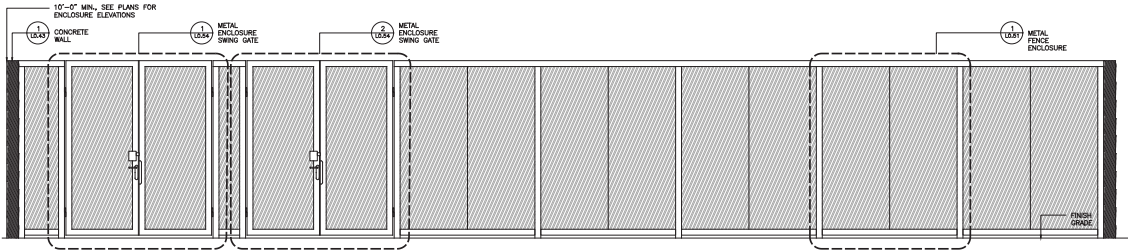

CURRENT NORTH ELEVATION

5TH STREET PUMP STATION CITYSIDE PARK

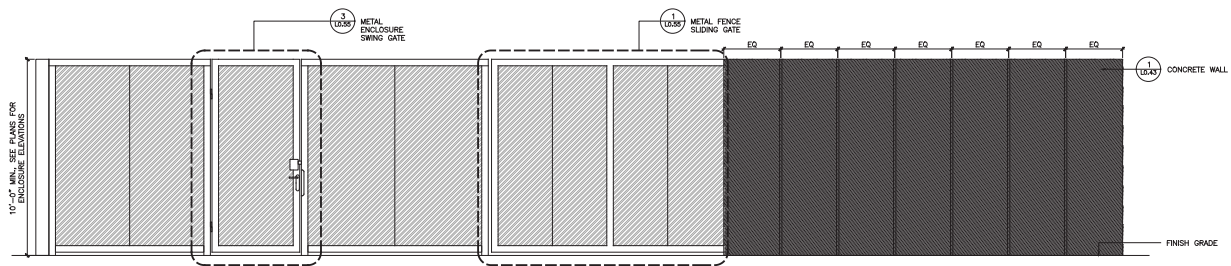
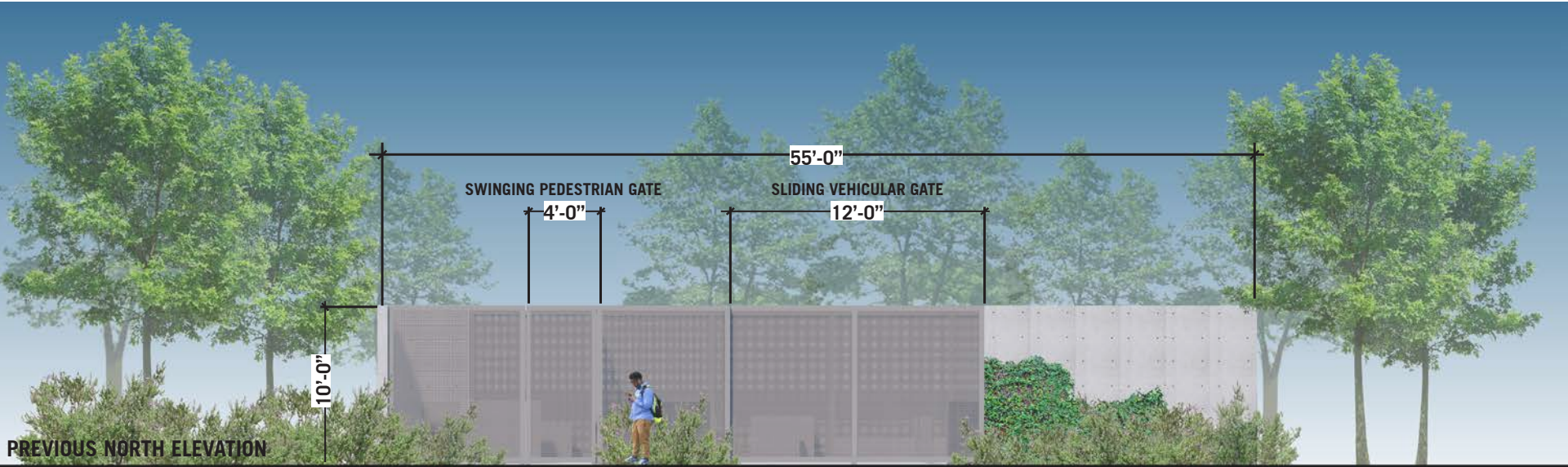

CURRENT NORTH ELEVATION

THANK YOU

