

BRIEF(S) SUBMITTED BY RESPONDENT DEPARTMENT(S)



Board of Appeals Brief

Date: June 3, 2021
Hearing Date: June 9, 2021
Appeal No.: 21-035
Address: 2722-2724 Folsom Street
Block/Lot: 3641 / 002
Zoning/Height: RH-2 (Residential – House, Two-Family)
40-X Height and Bulk District
Staff Contact: Scott Sanchez, (628) 652-7320 or scott.sanchez@sfgov.org

INTRODUCTION

This appeal arises from the permit applicant’s refusal to correct inconsistencies between the permit applications at issue and the existing conditions at the subject property. The Appellant goes even further, arguing that it can merge an Unauthorized Dwelling Unit (UDU) into an existing legal dwelling unit by simply changing the label on its permit plans from “kitchen” to “laundry” without benefit of proper permits or the required Conditional Use Authorization (CUA) under Planning Code Section 317¹. But this argument is inconsistent with both the Planning Code, and the prior admissions of Appellant’s counsel in a related appeal to this Board. Because the Appellant has refused to correct the violation by providing accurate information to correct inconsistencies between its permit applications and the site conditions relating to a kitchen in the UDU at the property, the Board should deny the appeal and uphold the Suspension Request.

On April 9, 2021, Ryan Patterson on behalf of Michael Turon (Appellant) filed Appeal No. 21-035 appealing the Acting Zoning Administrator’s issuance of a Suspension Request for Building Permit Application (BPA) Nos. 202006118414 and 202010055941 (Permits) for the property at 2722-2724 Folsom Street (Property).

¹ Pursuant to Planning Code Section 317, a CUA is required for merger, conversion or demolition of a legal dwelling unit or removal of a UDU. The findings differ for each and are outlined in Planning Code Section 317(g).

The Suspension Request identified specific inconsistencies between the existing conditions as shown on the Permits with those shown on prior permits and provided the Appellant with time to address those inconsistencies and correct any resulting misrepresentation in the permit applications. The Appellant has failed to demonstrate that the Acting Zoning Administrator erred or abused their discretion in issuing the Suspension Request, failed to demonstrate that the subject permits were properly issued, and refuses to provide the Zoning Administrator with corrected permit documents reflecting the existing project conditions.

PROPERTY INFORMATION

The Property is located at 2722-2724 Folsom Street within the RH-2 Zoning District and 40-X Height and Bulk District. The subject building was constructed circa 1896 and contains 4,375 square feet (per Assessor's records) and two legal dwelling units. Prior to 2019, records of the Department of Building Inspection (DBI) indicated that the Property contained three legal dwelling units. Following additional research of the Property's permit history, DBI corrected the record and the Appellant obtained a permit to document that the Property contains two legal dwelling units.

Since 2016, the property owner has sought more than 25 building permits for the Property (Exhibit A). In 2017, the Property owner sought a CUA from the Planning Commission to merge two dwelling units on the ground floor of the Property (at that time DBI records indicated the property contained three legal dwelling units). The Commission denied that CUA. After a fire damaged a kitchen in one of the ground floor dwelling units in 2018, the Appellant subsequently applied for and then withdrew two separate building permits that referenced removal of the kitchen. By the permits at issue here, the Appellant seeks to obtain the result previously denied by the Commission by simply relabeling its building plans from "kitchen" to "laundry" without benefit of proper permits or the required CUA.

BACKGROUND

In 2016, DBI records indicated the property contained three legal dwelling units.

On February 8, 2016, the Appellant submitted BPA No. 201602089084 to merge the two ground floor dwelling units on the Property, reducing the number of dwelling units on the Property from three to two (one on the ground floor and one on the first floor). Such merger required a CUA under Planning Code Section 317. This permit was withdrawn on February 24, 2016.

On March 3, 2016, the Appellant filed a CUA application pursuant to Section 317 to merge the two ground floor dwelling units on the Property (Case No. 2016-002914CUA).

On March 10, 2016, the Appellant submitted BPA No. 201603101720 to merge the two ground floor dwelling units on the Property.

On December 21, 2017, the Planning Commission held a public hearing on Case No. 2016-002914CUA and denied the request to merge the two ground floor dwelling units (Motion No. 20084). Plans on file with this case identified 2724 Folsom Street #A as the “Front Ground Unit” and 2724 Folsom Street #B as the “Back Ground Unit.” As shown on the plans, each unit had its own entrance, kitchen, and bathing facilities (Exhibit B). Based upon their application, both units were occupied at the time of the application.

On January 22, 2018, the Appellant attempted to appeal the Planning Commission’s denial of the CUA to the Board of Supervisors.

On January 26, 2018, the Board of Supervisors indicated that the attempted appeal of the CUA did not meet the requirements of Planning Code Section 308.1, which establishes thresholds for when a CUA appeal may be accepted and heard by the Board of Supervisors.

On February 17, 2018, a fire occurred in the kitchen of the Front Ground Unit.

On February 21, 2018, DBI issued NOV 201842471 (Exhibit 12 of Appellant’s Brief) to document the fire and noting damage to wall and ceiling finishes and no structural damage.

On March 23, 2018, the Appellant submitted the following two building permit applications:

- 1) BPA No. 201803234527 to comply with NOV 201842471 to perform fire damage repairs and “remove unpermitted kitchen in front area of 1st fl unit” (Front Ground Unit). This permit was withdrawn on June 10, 2019.
- 2) BPA No. 201803234544 to document the legal use of the building as containing two dwelling units. The permit was subsequently denied by the DBI, whose records indicated the legal use of the building as containing three dwelling units.

On July 2, 2018, the Appellant appealed the denial of BPA No. 201803234544 to the Board of Appeals (Appeal No. 18-093).

On October 10, 2018, the Board of Appeals held public hearing on Appeal No. 18-093. At this hearing, the Appellant argued that the Property contained two legal dwelling units, not three legal dwelling units as indicated in DBI records. At this hearing, the Planning Department noted that even if the Board granted the appeal and found the Property contained two legal dwelling units, a CUA would be required for the removal of a UDU pursuant to Planning Code Section 317 if the Appellant sought to retain only the two legal dwelling units on the Property. In response, the Appellant’s attorney (Ryan Patterson) acknowledged this prospect and stated the following:

“First off, the Zoning Administrator's comment that even if the Board were to overturn this denial and issue the permit then we would have to go into the Section 317 process. I think that’s correct. And the answer is the Board should overturn the denial and then we go into this Section 317 process. And Planning can decide if they want to seek legalization as an ADU or what not. That is the appropriate process to be going through. The question of whether there's an assumption of this unit being lawful or not, based on lack of evidence, there's a lot of evidence showing that this is not a lawful unit here. So that's the right process and if you overturn the denial, you are not sentencing this unit to disappear forever.”

At the close of the hearing, the Board upheld the denial of BPA No. 201803234544, which confirmed the legal use of the property as containing three dwelling units.

On May 21, 2019, following additional review of their records, DBI issued BPA No. 201905211330 to document the legal use of the building as containing two dwelling units to correct errors on previously issued permits from 1975 to present. This permit was for administrative purposes only and did not include any plans of the building.

On August 2, 2019, the Appellant submitted BPA No. 201908027791 to comply with DBI NOV 201842471 to perform fire damage repairs. This scope of work also stated: “not reinstalling 2nd kitchen which was destroyed by fire at northeast of the 1st floor unit” (Front Ground Unit). This permit was withdrawn by the Appellant on March 4, 2020.

On March 6, 2020, the Appellant submitted BPA No. 20200306357 to comply with NOV 201842471 to perform fire damage repairs and install new sheetrock with no structural work. Notably, this permit omitted key language found in previous permits regarding removal of the kitchen in the Front Ground Unit. In reviewing this permit, then-Senior Building Inspector Joseph Duffy asked the Appellant to specify the area of the building in which they were doing the work, to which they replied the laundry area. In response, Mr. Duffy noted that the work would be done in the laundry area. This permit did not include any plans and did not authorize the removal or change in use of the kitchen.

On June 11, 2020, the Appellant submitted BPA No. 202006118414 to repair fire damage and remodel the ground floor of the subject property. On this permit, the kitchen for the Front Ground Unit is shown as an existing laundry room. No permit was issued that authorizes the removal of this kitchen and its replacement with a laundry room. As such, the plans on file with BPA No. 202006118414 misrepresent the existing conditions of the subject property.

On October 5, 2020, the Appellant submitted BPA No. 202010055941 to revise BPA No. 202006118414 to alter the proposed floor plan. On this permit, the kitchen for the Front Ground Unit is still shown as an existing laundry room. No permit was issued that authorizes the removal of this kitchen and its replacement

with a laundry room. As such, the plans on file with BPA No. 202010055941 misrepresent the existing conditions of the subject property.

On April 8, 2021, the Acting Zoning Administrator issued a Suspension Request for the Permits due to inconsistencies between the existing conditions as shown on the Permits with those shown on prior permits and provided the Appellant with time to address those inconsistencies and correct any misrepresentations of these conditions caused by the plan inconsistencies.

On April 9, 2021, the Appellant filed Appeal No. 21-035.

On April 16, 2021, the Appellant's attorney submitted a letter to the Planning Department in response to the Suspension Request. In discussing the change from "kitchen" to "laundry" identified in the Suspension Request, counsel stated that BPA No. 202003066357 "changed any such room designation to 'laundry'." In support of this argument, they cited the fact that the permit was reviewed by then-Senior Inspector Joseph Duffy at DBI who wrote "all work in Laundry area only. 90 sq ft s/rock replacement, approx."

On April 30, 2021, Acting Chief Building Inspector Joseph Duffy wrote an email to the Appellant's attorney (Exhibit C) stating unequivocally that BPA No. 202003066357 "did not authorize the space to be designated as a laundry area." Further, Mr. Duffy stated that this language was added to the permit because he had asked the Appellant to specify the area of the building in which they were doing the work in order to provide information missing from the application, to which they replied the laundry area.

ISSUES ON APPEAL

A. Appellant Has Not Obtained a CUA to Remove the UDU at the Property.

On May 20, 2021, the Appellant filed a brief for Appeal No. 21-035. Appellant's brief fails to show that the Acting Zoning Administrator erred or abused their discretion in issuing the Suspension Request and failed to demonstrate that the subject permits were properly issued.

The Appellant argues that BPA No. 202003066357 authorized the change in designation of the kitchen to a laundry; however, this is incorrect. In fact, on April 30, 2021, Acting Chief Building Inspector Duffy informed the Appellant’s attorney that this permit “did not authorize the space to be designated as a laundry area.” Despite receiving this information three weeks before submitting their brief, the Appellant failed to provide any response to DBI’s determination. The Appellant also failed to provide any other evidence of a permit authorizing a change from kitchen to laundry. Instead, the only permit applications that referenced removal of the previous kitchen (BPA No. 201908027791 [WITHDRAWN] and BPA No, 201803234527 [WITHDRAWN]) were withdrawn by Appellant. (See Exhibit A)

In support of its argument that it has already received authorization to remove the third kitchen, the Appellant argues that the Property legally contains two dwelling units. But this fact is not in dispute. The issue is that the unauthorized removal of the kitchen in the Front Ground Unit results in the removal of a UDU. In order to remove a UDU, Appellant must first obtain a CUA under Planning Code Section 317. This is confirmed by the Appellant’s own attorney in testimony offered before the Board of Appeals on October 10, 2018. In that testimony, Mr. Patterson conceded on behalf of Appellant that, even if the property was found to contain only two legal dwelling units, removal of the third unit would require a CUA under Section 317. In this case, the Appellant has not sought the required CUA to remove the UDU.

B. The Previous Lawsuit and Pending Permits are Irrelevant to This Appeal.

In their brief, the Appellant cites several documents that are irrelevant to the issues presented here. First, Appellant refers to a Stipulated Dismissal associated with a previous lawsuit. It is noted that the stipulation does not include any determinations allowing the removal of the kitchen in the Front Ground unit, the change in designation of the kitchen to laundry, or the removal of a UDU. Instead, the stipulation merely reflects the now undisputed fact that the property contains two legal units. It does not take any position regarding the legal status of the UDU, but merely notes that a fire had occurred in its kitchen. The Appellant

also cites recent activity on BPA No. 201807063908 (Garage Permit); however, the instant appeal does not involve this permit.

C. Appellant Cannot Obtain Vested Rights to a Permit Issued Based on Misrepresented Site Conditions.

The Appellant argues that they have vested rights to the Permits; this is incorrect. To establish vested rights in a permit, a plaintiff must prove it has performed substantial work and incurred substantial liabilities in good faith reliance upon a validly issued governmental permit. (*Avco Community Developers, Inc. v. South Coast Regional Com.* (1976) 17 Cal.3d 785, 791.) Appellant cannot claim good faith reliance on a permit that was issued on the basis of misrepresentations in its permit application. (See *Stokes v. Board of Permit Appeals* (1997) 52 Cal.App.4th 1348, 1353; *Autopsy/Post Services, Inc. v. City of Los Angeles* (2005) 129 Cal.App.4th 521, 523 [no vested right to use building for performing autopsies where permit applications never revealed that proposed use].) Here, the Permits misrepresent the existing ground floor conditions on the Property by showing a second ground floor kitchen as a laundry room. The Appellant argues that a separate permit changed the room designation from “kitchen” to “laundry”; however, the referenced permit makes no mention of this change and DBI has confirmed that this permit could not have authorized such a change. Whether these misrepresentations were intentional or not is irrelevant. The simple fact is that Appellant cannot establish good faith reliance on permits that were obtained on the basis of misrepresentations of site conditions.

CONCLUSION

In light of the foregoing, the Planning Department respectfully requests that the Board of Appeals deny the appeal and uphold the Acting Zoning Administrator’s Suspension Request for the Property.

Attachments:

Exhibit A: Building Permit Summary

Exhibit B: Case No. 2016-002914CUA Ground Floor Plans

Board of Appeals Brief
Appeal No. 21-035
2722-2724 Folsom Street
Hearing Date: June 9, 2021

Exhibit C: Email from Acting Chief Building Inspector Joseph Duffy (dated April 30, 2021)

Cc: Ryan Patterson, Attorney for Appellant (by email)

Exhibit A (Note: Some items in the list are duplicates)



Report for: **2722 FOLSOM ST**

Building Permits

Applications for Building Permits submitted to the Department of Building Inspection.

Active Permits

Permit 202010055941 [↗](#)

Status: SUSPEND

Status Date: 4/9/2021

Revision to pa 202006118414. Revised flr plan. Not adding previously proposed new full bathroom.

Performing voluntary seismic retrofit. No change in construction cost.

Originally Filed:	10/5/2020	Address:	2722 FOLSOM ST
Existing Use:	2 FAMILY DWELLING	Parcel:	3641/002
Proposed Use:	2 FAMILY DWELLING	Existing Units:	2
Construction Cost:	\$40,000.00	Proposed Units:	2

Permit 202010055941 [↗](#)

Status: SUSPEND

Status Date: 4/9/2021

Revision to pa 202006118414. Revised flr plan. Not adding previously proposed new full bathroom.

Performing voluntary seismic retrofit. No change in construction cost.

Originally Filed:	10/5/2020	Address:	2724 FOLSOM ST
Existing Use:	2 FAMILY DWELLING	Parcel:	3641/002
Proposed Use:	2 FAMILY DWELLING	Existing Units:	2
Construction Cost:	\$40,000.00	Proposed Units:	2

Permit 202006118414 [↗](#)

Status: SUSPEND

Status Date: 4/9/2021

Repair fire, smoke & water damage. No exterior work. Adding small 39 sf bathroom near existing bedroom.

Convert living room to family room, office to living and dining to study. All work is in unit 2724

Originally Filed:	6/11/2020	Address:	2724 FOLSOM ST
Existing Use:	2 FAMILY DWELLING	Parcel:	3641/002
Proposed Use:	2 FAMILY DWELLING	Existing Units:	2
Construction Cost:	\$158,000.00	Proposed Units:	2

Permit 202006118414 [↗](#)

Status: SUSPEND

Status Date: 4/9/2021

Repair fire, smoke & water damage. No exterior work. Adding small 39 sf bathroom near existing bedroom.

Convert living room to family room, office to living and dining to study. All work is in unit 2724

Originally Filed:	6/11/2020	Address:	2722 FOLSOM ST
--------------------------	-----------	-----------------	----------------

Exhibit A (Note: Some items in the list are duplicates)

Existing Use:	2 FAMILY DWELLING	Parcel:	3641/002
Proposed Use:	2 FAMILY DWELLING	Existing Units:	2
Construction Cost:	\$158,000.00	Proposed Units:	2

Permit 201807063908 [↗](#)

Status: PLANCHECK

Status Date: 12/23/2020

Restore historical element to building; restore historical and permitted garage.

Originally Filed:	7/6/2018	Address:	2722 FOLSOM ST
Existing Use:	APARTMENTS	Parcel:	3641/002
Proposed Use:	APARTMENTS	Existing Units:	3
Construction Cost:	\$25,000.00	Proposed Units:	3

Permit 201807063908 [↗](#)

Status: PLANCHECK

Status Date: 12/23/2020

Restore historical element to building; restore historical and permitted garage.

Originally Filed:	7/6/2018	Address:	2724 FOLSOM ST
Existing Use:	APARTMENTS	Parcel:	3641/002
Proposed Use:	APARTMENTS	Existing Units:	3
Construction Cost:	\$25,000.00	Proposed Units:	3

Completed Permits

Permit 202012211404 [↗](#)

Status: ISSUED

Status Date: 1/25/2021

Revision to pa 2020-0804-1014 (n) concrete foundations at (e) front stairs. (n)n framing as required

Originally Filed:	12/21/2020	Address:	2722 FOLSOM ST
Existing Use:	2 FAMILY DWELLING	Parcel:	3641/002
Proposed Use:	2 FAMILY DWELLING	Existing Units:	2
Construction Cost:	\$4,200.00	Proposed Units:	2

Permit 202012211404 [↗](#)

Status: ISSUED

Status Date: 1/25/2021

Revision to pa 2020-0804-1014 (n) concrete foundations at (e) front stairs. (n)n framing as required

Originally Filed:	12/21/2020	Address:	2724 FOLSOM ST
Existing Use:	2 FAMILY DWELLING	Parcel:	3641/002
Proposed Use:	2 FAMILY DWELLING	Existing Units:	2
Construction Cost:	\$4,200.00	Proposed Units:	2

Permit 202011199274 [↗](#)

Status: ISSUED

Status Date: 11/19/2020

Exhibit A (Note: Some items in the list are duplicates)

Replace windows (same size and location), total 12 windows not visible to street. Not vinyl exterior windows, fibrex.

Originally Filed:	11/19/2020	Address:	2724 FOLSOM ST
Existing Use:	2 FAMILY DWELLING	Parcel:	3641/002
Proposed Use:	2 FAMILY DWELLING	Existing Units:	2
Construction Cost:	\$5,000.00	Proposed Units:	2

Permit 202011199274 [↗](#)

Status: ISSUED

Status Date: 11/19/2020

Replace windows (same size and location), total 12 windows not visible to street. Not vinyl exterior windows, fibrex.

Originally Filed:	11/19/2020	Address:	2722 FOLSOM ST
Existing Use:	2 FAMILY DWELLING	Parcel:	3641/002
Proposed Use:	2 FAMILY DWELLING	Existing Units:	2
Construction Cost:	\$5,000.00	Proposed Units:	2

Permit 202011179062 [↗](#)

Status: ISSUED

Status Date: 12/1/2020

Revision to pa# 202010055941 & pa# 202006118414 underpinning of (e) longitudinal foundations and install (n) footing in rear correction of structural plan to match arch plan. No proposed architectural changes.

Originally Filed:	11/17/2020	Address:	2724 FOLSOM ST
Existing Use:	2 FAMILY DWELLING	Parcel:	3641/002
Proposed Use:	2 FAMILY DWELLING	Existing Units:	2
Construction Cost:	\$7,000.00	Proposed Units:	2

Permit 202011179062 [↗](#)

Status: ISSUED

Status Date: 12/1/2020

Revision to pa# 202010055941 & pa# 202006118414 underpinning of (e) longitudinal foundations and install (n) footing in rear correction of structural plan to match arch plan. No proposed architectural changes.

Originally Filed:	11/17/2020	Address:	2722 FOLSOM ST
Existing Use:	2 FAMILY DWELLING	Parcel:	3641/002
Proposed Use:	2 FAMILY DWELLING	Existing Units:	2
Construction Cost:	\$7,000.00	Proposed Units:	2

Permit 202009234778 [↗](#)

Status: ISSUED

Status Date: 9/23/2020

Revision to pa# 202006118414. Repair/reframe two entry doors located in unit 2724. Doors not visible from street. North & south exposure.

Originally Filed:	9/23/2020	Address:	2722 FOLSOM ST
Existing Use:	2 FAMILY DWELLING	Parcel:	3641/002
Proposed Use:	2 FAMILY DWELLING	Existing Units:	2
Construction Cost:	\$500.00	Proposed Units:	2

Exhibit A (Note: Some items in the list are duplicates)

Permit 202009234778 [↗](#)

Status: ISSUED

Status Date: 9/23/2020

Revision to pa# 202006118414. Repair/reframe two entry doors located in unit 2724. Doors not visible from street. North & south exposure.

Originally Filed:	9/23/2020	Address:	2724 FOLSOM ST
Existing Use:	2 FAMILY DWELLING	Parcel:	3641/002
Proposed Use:	2 FAMILY DWELLING	Existing Units:	2
Construction Cost:	\$500.00	Proposed Units:	2

Permit 202009043490 [↗](#)

Status: ISSUED

Status Date: 9/4/2020

Rev to 202006118414: replace (e) slab on grade. Note: during field repair, portions of exterior may be temporarily removed but will be returned when repair is completed.

Originally Filed:	9/4/2020	Address:	2722 FOLSOM ST
Existing Use:	2 FAMILY DWELLING	Parcel:	3641/002
Proposed Use:	2 FAMILY DWELLING	Existing Units:	2
Construction Cost:	\$5,000.00	Proposed Units:	2

Permit 202009043490 [↗](#)

Status: ISSUED

Status Date: 9/4/2020

Rev to 202006118414: replace (e) slab on grade. Note: during field repair, portions of exterior may be temporarily removed but will be returned when repair is completed.

Originally Filed:	9/4/2020	Address:	2724 FOLSOM ST
Existing Use:	2 FAMILY DWELLING	Parcel:	3641/002
Proposed Use:	2 FAMILY DWELLING	Existing Units:	2
Construction Cost:	\$5,000.00	Proposed Units:	2

Permit 202009043472 [↗](#)

Status: CANCELLED

Status Date: 9/30/2020

Revision to bpa# 202006118414. Replace existing slab-on-grade.

Originally Filed:	9/4/2020	Address:	2722 FOLSOM ST
Existing Use:	2 FAMILY DWELLING	Parcel:	3641/002
Proposed Use:	2 FAMILY DWELLING	Existing Units:	2
Construction Cost:	\$5,000.00	Proposed Units:	2

Permit 202009043472 [↗](#)

Status: CANCELLED

Status Date: 9/30/2020

Revision to bpa# 202006118414. Replace existing slab-on-grade.

Originally Filed:	9/4/2020	Address:	2724 FOLSOM ST
Existing Use:	2 FAMILY DWELLING	Parcel:	3641/002
Proposed Use:	2 FAMILY DWELLING	Existing Units:	2
Construction Cost:	\$5,000.00	Proposed Units:	2

Exhibit A (Note: Some items in the list are duplicates)

Permit 202008041014 [↗](#)

Status: ISSUED

Status Date: 8/4/2020

Repair front stairs less than 50%. Ref 18mse-0541 for approved sidewalk encroachment (3'x7.2') for base of stairs. Portions of stairs and front fence maybe temporarily removed during repair but will be returned when repair is completed.

Originally Filed:	8/4/2020	Address:	2724 FOLSOM ST
Existing Use:	2 FAMILY DWELLING	Parcel:	3641/002
Proposed Use:	2 FAMILY DWELLING	Existing Units:	2
Construction Cost:	\$5,000.00	Proposed Units:	2

Permit 202008041014 [↗](#)

Status: ISSUED

Status Date: 8/4/2020

Repair front stairs less than 50%. Ref 18mse-0541 for approved sidewalk encroachment (3'x7.2') for base of stairs. Portions of stairs and front fence maybe temporarily removed during repair but will be returned when repair is completed.

Originally Filed:	8/4/2020	Address:	2722 FOLSOM ST
Existing Use:	2 FAMILY DWELLING	Parcel:	3641/002
Proposed Use:	2 FAMILY DWELLING	Existing Units:	2
Construction Cost:	\$5,000.00	Proposed Units:	2

Permit 202008041013 [↗](#)

Status: ISSUED

Status Date: 8/4/2020

Unit # 2724: remove fire damage inside to estimate scope of plumbing and electrical work that will be performed under bpa# 202006118414. Around 200 sqft to be removed.

Originally Filed:	8/4/2020	Address:	2724 FOLSOM ST
Existing Use:	2 FAMILY DWELLING	Parcel:	3641/002
Proposed Use:	2 FAMILY DWELLING	Existing Units:	2
Construction Cost:	\$2,000.00	Proposed Units:	2

Permit 202006048167 [↗](#)

Status: ISSUED

Status Date: 6/15/2020

All work in unit 2722: remodel in-kind two bathrooms on the south side of the 2nd floor.

Originally Filed:	6/4/2020	Address:	2722 FOLSOM ST
Existing Use:	2 FAMILY DWELLING	Parcel:	3641/002
Proposed Use:	2 FAMILY DWELLING	Existing Units:	2
Construction Cost:	\$24,000.00	Proposed Units:	2

Permit 202006048167 [↗](#)

Status: ISSUED

Status Date: 6/15/2020

All work in unit 2722: remodel in-kind two bathrooms on the south side of the 2nd floor.

Originally Filed:	6/4/2020	Address:	2724 FOLSOM ST
Existing Use:	2 FAMILY DWELLING	Parcel:	3641/002

Exhibit A (Note: Some items in the list are duplicates)

Proposed Use: 2 FAMILY DWELLING **Existing Units:** 2
Construction Cost: \$24,000.00 **Proposed Units:** 2

Permit 202003066357 [↗](#)

Status: COMPLETE **Status Date:** 3/26/2020

To comply with nov 201842471; fire damage repair and install new sheet rock in ne corner only, no structural work, all work in laundry area only 90 sqft s/rock replacement approx

Originally Filed: 3/6/2020 **Address:** 2722 FOLSOM ST
Existing Use: 2 FAMILY DWELLING **Parcel:** 3641/002
Proposed Use: 2 FAMILY DWELLING **Existing Units:** 2
Construction Cost: \$1,750.00 **Proposed Units:** 2

Permit 202003066357 [↗](#)

Status: COMPLETE **Status Date:** 3/26/2020

To comply with nov 201842471; fire damage repair and install new sheet rock in ne corner only, no structural work, all work in laundry area only 90 sqft s/rock replacement approx

Originally Filed: 3/6/2020 **Address:** 2724 FOLSOM ST
Existing Use: 2 FAMILY DWELLING **Parcel:** 3641/002
Proposed Use: 2 FAMILY DWELLING **Existing Units:** 2
Construction Cost: \$1,750.00 **Proposed Units:** 2

Permit 202003046121 [↗](#)

Status: COMPLETE **Status Date:** 3/6/2020

To obtain final inspection for work approved under pa #201103293028. All work is complete. See pa #201905211330.

Originally Filed: 3/4/2020 **Address:** 2724 FOLSOM ST
Existing Use: 2 FAMILY DWELLING **Parcel:** 3641/002
Proposed Use: 2 FAMILY DWELLING **Existing Units:** 2
Construction Cost: \$1.00 **Proposed Units:** 2

Permit 202003046121 [↗](#)

Status: COMPLETE **Status Date:** 3/6/2020

To obtain final inspection for work approved under pa #201103293028. All work is complete. See pa #201905211330.

Originally Filed: 3/4/2020 **Address:** 2722 FOLSOM ST
Existing Use: 2 FAMILY DWELLING **Parcel:** 3641/002
Proposed Use: 2 FAMILY DWELLING **Existing Units:** 2
Construction Cost: \$1.00 **Proposed Units:** 2

Permit 201908027791 [↗](#)

Status: WITHDRAWN **Status Date:** 3/4/2020

Exhibit A (Note: Some items in the list are duplicates)

Comply with nov 201842471 to perform fire damage repairs. Not reinstalling illegal 2nd kitchen which was destroyed by fire at northeast of the 1st floor unit (2724 folsom st)

Originally Filed:	8/2/2019	Address:	2724 FOLSOM ST
Existing Use:	2 FAMILY DWELLING	Parcel:	3641/002
Proposed Use:	2 FAMILY DWELLING	Existing Units:	2
Construction Cost:	\$10,000.00	Proposed Units:	2

Permit 201908027791 [↗](#)

Status: WITHDRAWN

Status Date: 3/4/2020

Comply with nov 201842471 to perform fire damage repairs. Not reinstalling illegal 2nd kitchen which was destroyed by fire at northeast of the 1st floor unit (2724 folsom st)

Originally Filed:	8/2/2019	Address:	2722 FOLSOM ST
Existing Use:	2 FAMILY DWELLING	Parcel:	3641/002
Proposed Use:	2 FAMILY DWELLING	Existing Units:	2
Construction Cost:	\$10,000.00	Proposed Units:	2

Permit 201905211330 [↗](#)

Status: COMPLETE

Status Date: 5/22/2019

To document the legal use and occupancy of this bldg as a 3 story bldg. Containing 2 res. Dwelling units. This permit corrects errors on previously issued permits from 1975 to present. Pa 449293 was issued on 12/8/75 & a cfc issued by dbi. The owner at that time was aware that the bldg was not

Originally Filed:	5/21/2019	Address:	2724 FOLSOM ST
Existing Use:	2 FAMILY DWELLING	Parcel:	3641/002
Proposed Use:	2 FAMILY DWELLING	Existing Units:	2
Construction Cost:	\$1.00	Proposed Units:	2

Permit 201905211330 [↗](#)

Status: COMPLETE

Status Date: 5/22/2019

To document the legal use and occupancy of this bldg as a 3 story bldg. Containing 2 res. Dwelling units. This permit corrects errors on previously issued permits from 1975 to present. Pa 449293 was issued on 12/8/75 & a cfc issued by dbi. The owner at that time was aware that the bldg was not

Originally Filed:	5/21/2019	Address:	2722 FOLSOM ST
Existing Use:	2 FAMILY DWELLING	Parcel:	3641/002
Proposed Use:	2 FAMILY DWELLING	Existing Units:	2
Construction Cost:	\$1.00	Proposed Units:	2

Permit 201809140154 [↗](#)

Status: COMPLETE

Status Date: 6/18/2019

Rear structure: no dwelling units in rear structure, rear structure accessory structure to front building. Replace (e) tile floor in bathroom, vanity in bathroom, cabinet in work room/storage.

Originally Filed:	9/14/2018	Address:	2724 FOLSOM ST
Existing Use:	STORAGE SHED	Parcel:	3641/002
Proposed Use:	STORAGE SHED	Existing Units:	0

Exhibit A (Note: Some items in the list are duplicates)

Construction Cost: \$500.00 **Proposed Units:** 0

Permit 201809140154 [↗](#)

Status: COMPLETE

Status Date: 6/18/2019

Rear structure: no dwelling units in rear structure, rear structure accessory structure to front building. Replace (e) tile floor in bathroom, vanity in bathroom, cabinet in work room/storage.

Originally Filed:	9/14/2018	Address:	2722 FOLSOM ST
Existing Use:	STORAGE SHED	Parcel:	3641/002
Proposed Use:	STORAGE SHED	Existing Units:	0
Construction Cost:	\$500.00	Proposed Units:	0

Permit 201808107022 [↗](#)

Status: COMPLETE

Status Date: 8/23/2018

Rear structure/no dwelling units: remove non load bearing wall in permitted rear structure/workshop and storage. Rear structure is a legal (e) accessory structure which is an accesspry to the main bld. Front structure contains 3 legal units

Originally Filed:	8/10/2018	Address:	2722 FOLSOM ST
Existing Use:	STORAGE SHED	Parcel:	3641/002
Proposed Use:	STORAGE SHED	Existing Units:	0
Construction Cost:	\$350.00	Proposed Units:	0

Permit 201808107022 [↗](#)

Status: COMPLETE

Status Date: 8/23/2018

Rear structure/no dwelling units: remove non load bearing wall in permitted rear structure/workshop and storage. Rear structure is a legal (e) accessory structure which is an accesspry to the main bld. Front structure contains 3 legal units

Originally Filed:	8/10/2018	Address:	2724 FOLSOM ST
Existing Use:	STORAGE SHED	Parcel:	3641/002
Proposed Use:	STORAGE SHED	Existing Units:	0
Construction Cost:	\$350.00	Proposed Units:	0

Permit 201804065675 [↗](#)

Status: COMPLETE

Status Date: 4/11/2018

Remove fire damaged lath & plaster &/or drywall (~10 lf) along w/ fire damaged cabinets & counters to expose rough plumbing & electrical to estimate scope of repair to be performed on future permit. No elect/plumb work will be performed on this permit. No exterior work to be performed.

Originally Filed:	4/6/2018	Address:	2722 FOLSOM ST
Existing Use:	APARTMENTS	Parcel:	3641/002
Proposed Use:	APARTMENTS	Existing Units:	3
Construction Cost:	\$500.00	Proposed Units:	3

Permit 201804065675 [↗](#)

Exhibit A (Note: Some items in the list are duplicates)

Status: COMPLETE

Status Date: 4/11/2018

Remove fire damaged lath & plaster &/or drywall (~10 lf) along w/ fire damaged cabinets & counters to expose rough plumbing & electrical to estimate scope of repair to be performed on future permit. No elect/plumb work will be performed on this permit. No exterior work to be performed.

Originally Filed: 4/6/2018

Address: 2724 FOLSOM ST

Existing Use: APARTMENTS

Parcel: 3641/002

Proposed Use: APARTMENTS

Existing Units: 3

Construction Cost: \$500.00

Proposed Units: 3

Permit 201803234544 [↗](#)

Status: DENIED

Status Date: 2/20/2020

For administrative purpose only to document the legal use and occupancy of this building as a 2-story, w/2-residential dwelling units; correcting previously issued cfc. This determination is based on a review of city records including sanborn maps, assessors records, bldg permits & housing records.

Originally Filed: 3/23/2018

Address: 2722 FOLSOM ST

Existing Use: APARTMENTS

Parcel: 3641/002

Proposed Use: 2 FAMILY DWELLING

Existing Units: 3

Construction Cost: \$1.00

Proposed Units: 2

Permit 201803234544 [↗](#)

Status: DENIED

Status Date: 2/20/2020

For administrative purpose only to document the legal use and occupancy of this building as a 2-story, w/2-residential dwelling units; correcting previously issued cfc. This determination is based on a review of city records including sanborn maps, assessors records, bldg permits & housing records.

Originally Filed: 3/23/2018

Address: 2724 FOLSOM ST

Existing Use: APARTMENTS

Parcel: 3641/002

Proposed Use: 2 FAMILY DWELLING

Existing Units: 3

Construction Cost: \$1.00

Proposed Units: 2

Permit 201803234527 [↗](#)

Status: WITHDRAWN

Status Date: 6/10/2019

Comply with nov 201842471. Repair fire damage and bring building into code compliance. Remove unpermitted kitchen in front area of 1st fl unit. Bring kitchen in rear of 1st fl up to code. Repair lath and plaster damaged in fire

Originally Filed: 3/23/2018

Address: 2724 FOLSOM ST

Existing Use: APARTMENTS

Parcel: 3641/002

Proposed Use: 2 FAMILY DWELLING

Existing Units: 3

Construction Cost: \$30,000.00

Proposed Units: 2

Permit 201803234527 [↗](#)

Status: WITHDRAWN

Status Date: 6/10/2019

Comply with nov 201842471. Repair fire damage and bring building into code compliance. Remove unpermitted kitchen in front area of 1st fl unit. Bring kitchen in rear of 1st fl up to code. Repair lath and plaster

Exhibit A (Note: Some items in the list are duplicates)

damaged in fire

Originally Filed:	3/23/2018	Address:	2722 FOLSOM ST
Existing Use:	APARTMENTS	Parcel:	3641/002
Proposed Use:	2 FAMILY DWELLING	Existing Units:	3
Construction Cost:	\$30,000.00	Proposed Units:	2

Permit 201802222028 [↗](#)

Status: COMPLETE

Status Date: 2/26/2018

Repair door jam to "correct front door on 2nd floor within 48 hrs" per nov #201842471. Door damaged by sffd due to fire on 2/17/2018. See sffd incident #18020623. Corrective action per sfbc 104a.2.4

Originally Filed:	2/22/2018	Address:	2722 FOLSOM ST
Existing Use:	APARTMENTS	Parcel:	3641/002
Proposed Use:	APARTMENTS	Existing Units:	3
Construction Cost:	\$200.00	Proposed Units:	3

Permit 201802222028 [↗](#)

Status: COMPLETE

Status Date: 2/26/2018

Repair door jam to "correct front door on 2nd floor within 48 hrs" per nov #201842471. Door damaged by sffd due to fire on 2/17/2018. See sffd incident #18020623. Corrective action per sfbc 104a.2.4

Originally Filed:	2/22/2018	Address:	2724 FOLSOM ST
Existing Use:	APARTMENTS	Parcel:	3641/002
Proposed Use:	APARTMENTS	Existing Units:	3
Construction Cost:	\$200.00	Proposed Units:	3

Permit 201802131149 [↗](#)

Status: COMPLETE

Status Date: 2/15/2018

To comply w/ nov #201840531 items 3, 4 install handrail on rear stairs. Replace in-kind 2x4 guard rail w/ dry rot. Replace in-kind one 2x10 pressure treated stair trend. Please see 02/12/18 letter given to his. Repair in-kind. No work visible from the street.

Originally Filed:	2/13/2018	Address:	2722 FOLSOM ST
Existing Use:	APARTMENTS	Parcel:	3641/002
Proposed Use:	APARTMENTS	Existing Units:	3
Construction Cost:	\$850.00	Proposed Units:	3

Permit 201802131149 [↗](#)

Status: COMPLETE

Status Date: 2/15/2018

To comply w/ nov #201840531 items 3, 4 install handrail on rear stairs. Replace in-kind 2x4 guard rail w/ dry rot. Replace in-kind one 2x10 pressure treated stair trend. Please see 02/12/18 letter given to his. Repair in-kind. No work visible from the street.

Originally Filed:	2/13/2018	Address:	2724 FOLSOM ST
Existing Use:	APARTMENTS	Parcel:	3641/002
Proposed Use:	APARTMENTS	Existing Units:	3

Exhibit A (Note: Some items in the list are duplicates)

Construction Cost: \$850.00 **Proposed Units:** 3

Permit 201712186772 [↗](#)

Status: COMPLETE

Status Date: 1/25/2018

Remove 2 illegal units (unit 4 "attic"& unit 5 "cottage/rear shed") that have no path for legalization per sfbc 106a.3.1.3 & exempt from conditional use authorization per planning code 317(c)(4). Remove gas stove from rear shed and revert to last legal use (pa 259518) & remove elec stove in attic.

Originally Filed:	12/18/2017	Address:	2722 FOLSOM ST
Existing Use:	APARTMENTS	Parcel:	3641/002
Proposed Use:	APARTMENTS	Existing Units:	3
Construction Cost:	\$3,000.00	Proposed Units:	3

Permit 201712186772 [↗](#)

Status: COMPLETE

Status Date: 1/25/2018

Remove 2 illegal units (unit 4 "attic"& unit 5 "cottage/rear shed") that have no path for legalization per sfbc 106a.3.1.3 & exempt from conditional use authorization per planning code 317(c)(4). Remove gas stove from rear shed and revert to last legal use (pa 259518) & remove elec stove in attic.

Originally Filed:	12/18/2017	Address:	2724 FOLSOM ST
Existing Use:	APARTMENTS	Parcel:	3641/002
Proposed Use:	APARTMENTS	Existing Units:	3
Construction Cost:	\$3,000.00	Proposed Units:	3

Permit 201710242108 [↗](#)

Status: CANCELLED

Status Date: 3/6/2018

Removal of stoves in attic & cottage unit. Dbi has determined "no path for legalization " under building code, (attache pre app) planning has determined that under planning code sec 317 no cu hearing is required,(attch letter)under dispute with filing to dbi rmd,units illegal (2) to be removed

Originally Filed:	10/24/2017	Address:	2724 FOLSOM ST
Existing Use:	APARTMENTS	Parcel:	3641/002
Proposed Use:	APARTMENTS	Existing Units:	5
Construction Cost:	\$2,000.00	Proposed Units:	3

Permit 201710242108 [↗](#)

Status: CANCELLED

Status Date: 3/6/2018

Removal of stoves in attic & cottage unit. Dbi has determined "no path for legalization " under building code, (attache pre app) planning has determined that under planning code sec 317 no cu hearing is required,(attch letter)under dispute with filing to dbi rmd,units illegal (2) to be removed

Originally Filed:	10/24/2017	Address:	2722 FOLSOM ST
Existing Use:	APARTMENTS	Parcel:	3641/002
Proposed Use:	APARTMENTS	Existing Units:	5
Construction Cost:	\$2,000.00	Proposed Units:	3

Exhibit A (Note: Some items in the list are duplicates)

Permit 201603101720 [↗](#)

Status: CANCELLED

Status Date: 2/6/2018

Dwelling unit removal - merger of two of the three units to create a 2 unit building. Remove one of the existing legal kitchen on ground floor

Originally Filed:	3/10/2016	Address:	2722 FOLSOM ST
Existing Use:	APARTMENTS	Parcel:	3641/002
Proposed Use:	2 FAMILY DWELLING	Existing Units:	3
Construction Cost:	\$5,000.00	Proposed Units:	2

Permit 201602089084 [↗](#)

Status: WITHDRAWN

Status Date: 2/24/2016

Dwelling unit removal - merger of (2) of the (3) units to create a (2) unit. Remove & cap (e) legal kitchen.

Originally Filed:	2/8/2016	Address:	2722 FOLSOM ST
Existing Use:	APARTMENTS	Parcel:	3641/002
Proposed Use:	2 FAMILY DWELLING	Existing Units:	3
Construction Cost:	\$5,000.00	Proposed Units:	2

Permit 201201132234 [↗](#)

Status: COMPLETE

Status Date: 3/15/2012

Replace existing 6 alum horizontal sliding door with new white vinyl of same, replace in kind and type in value .35, not visible from street

Originally Filed:	1/13/2012	Address:	2722 FOLSOM ST
Existing Use:	APARTMENTS	Parcel:	3641/002
Proposed Use:	APARTMENTS	Existing Units:	3
Construction Cost:	\$1,500.00	Proposed Units:	3

Permit 201103293028 [↗](#)

Status: ISSUED

Status Date: 3/29/2011

Work on #2722 - install new tub with new value, rerframe tub wall, install new tile, install 1 gfi.

Originally Filed:	3/29/2011	Address:	2724 FOLSOM ST
Existing Use:	APARTMENTS	Parcel:	3641/002
Proposed Use:	APARTMENTS	Existing Units:	3
Construction Cost:	\$2,800.00	Proposed Units:	3

Permit 201103293028 [↗](#)

Status: ISSUED

Status Date: 3/29/2011

Work on #2722 - install new tub with new value, rerframe tub wall, install new tile, install 1 gfi.

Originally Filed:	3/29/2011	Address:	2722 FOLSOM ST
Existing Use:	APARTMENTS	Parcel:	3641/002
Proposed Use:	APARTMENTS	Existing Units:	3
Construction Cost:	\$2,800.00	Proposed Units:	3

Exhibit A (Note: Some items in the list are duplicates)

Permit 201004059649 [↗](#)

Status: COMPLETE

Status Date: 4/15/2010

Reroofing

Originally Filed: 4/5/2010

Address: 2722 FOLSOM ST

Existing Use: 1 FAMILY DWELLING

Parcel: 3641/002

Proposed Use: 1 FAMILY DWELLING

Existing Units: 1

Construction Cost: \$2,800.00

Proposed Units: 1

Permit 201003238760 [↗](#)

Status: COMPLETE

Status Date: 3/30/2010

Sister 2x4 rafter approx 4' & re-sheetrock ceiling. Tape & paint

Originally Filed: 3/23/2010

Address: 2724 FOLSOM ST

Existing Use: APARTMENTS

Parcel: 3641/002

Proposed Use: APARTMENTS

Existing Units: 3

Construction Cost: \$600.00

Proposed Units: 3

Permit 201003238760 [↗](#)

Status: COMPLETE

Status Date: 3/30/2010

Sister 2x4 rafter approx 4' & re-sheetrock ceiling. Tape & paint

Originally Filed: 3/23/2010

Address: 2722 FOLSOM ST

Existing Use: APARTMENTS

Parcel: 3641/002

Proposed Use: APARTMENTS

Existing Units: 3

Construction Cost: \$600.00

Proposed Units: 3

Permit 201003097807 [↗](#)

Status: WITHDRAWN

Status Date: 2/18/2020

Repair approx. 3-broken roof rafters damaged by falling tree branch @ 1-family cottage in rear yard.

Originally Filed: 3/9/2010

Address: 2722 FOLSOM ST

Existing Use: 1 FAMILY DWELLING

Parcel: 3641/002

Proposed Use: 1 FAMILY DWELLING

Existing Units: 1

Construction Cost: \$1,500.00

Proposed Units: 1

Permit 200601192481 [↗](#)

Status: COMPLETE

Status Date: 3/13/2006

Reroofing

Originally Filed: 1/19/2006

Address: 2722 FOLSOM ST

Existing Use: 2 FAMILY DWELLING

Parcel: 3641/002

Proposed Use: 2 FAMILY DWELLING

Existing Units: 0

Construction Cost: \$2,800.00

Proposed Units: 0

Permit 8608636 [↗](#)

Exhibit A (Note: Some items in the list are duplicates)

Status: EXPIRED

Status Date: 7/15/1993

To bring building into full compliance as required by dahi

Originally Filed: 7/18/1986

Address: 2722 FOLSOM ST

Existing Use: APARTMENTS

Parcel: 3641/002

Proposed Use: APARTMENTS

Existing Units: 4

Construction Cost: \$1,000.00

Proposed Units: 3

Additional Permits

Additional Permits [🔗](#) (electrical, plumbing, etc) lodged with the Department of Building Inspections.

Exhibit B



Drawing Index:

- A1 Site Plan
- A2 Existing Floor Plans
- A3 Existing Floor Plans
- A4 Proposed Floor Plans
- A5 Proposed Floor Plans

EXISTING FIRST FLOOR PLAN
1/4" = 1'-0"

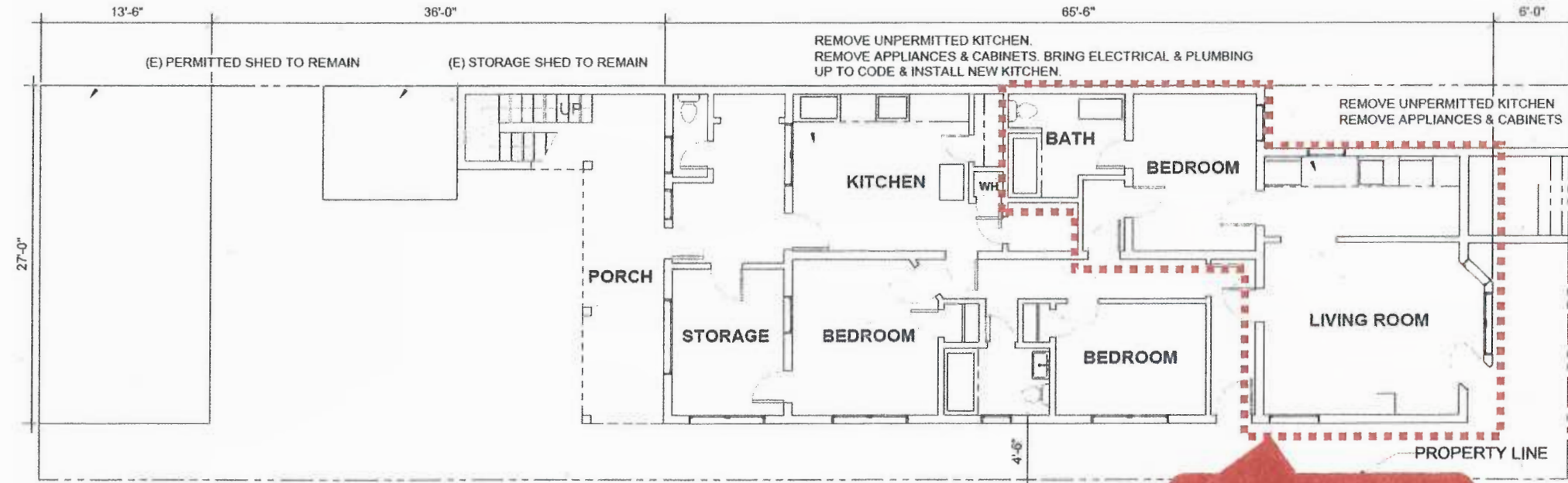

EXISTING GROUND FLOOR PLAN
1/4" = 1'-0"

2724 Folsom #A:
"Front Ground Unit"

David Locicero
architect
California Registration C19452

2340 Powell Street, No. 290
Emeryville, CA 94608
415.342.2204
d.locicero@gmail.com
www.dslociceroarchitect.com

2722 - 2724 Folsom Street
3- UNIT TO 2- UNIT
CONVERSION

Michael Turon
2722 - 2724 Folsom Street
San Francisco, CA 94110
turon@cantab.net

Copyright David Locicero, ALL RIGHTS RESERVED. The
project drawings and/or text are the sole property of
David Locicero. If you wish to reproduce or use these
drawings in any way, please contact David Locicero at
d.locicero@gmail.com

Stamp



7/12/2017
As Noted
DSL Locicero
DSL Locicero
1706
Checked By:
Job Number

SHEET TITLE
A-2

Exhibit B

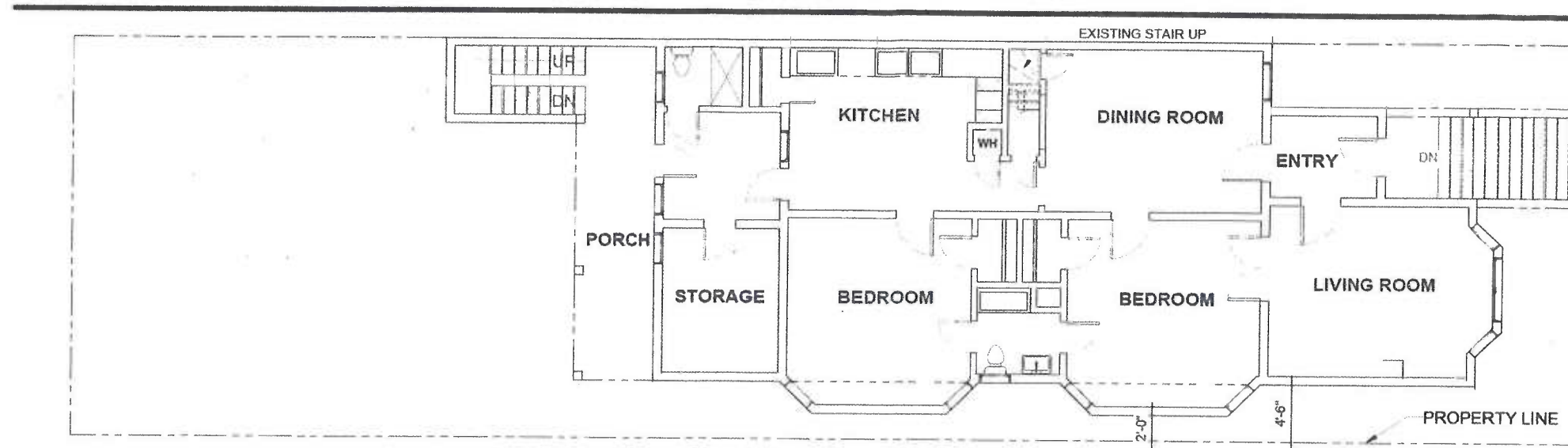

EXISTING FIRST FLOOR PLAN
1/4" = 1'-0"

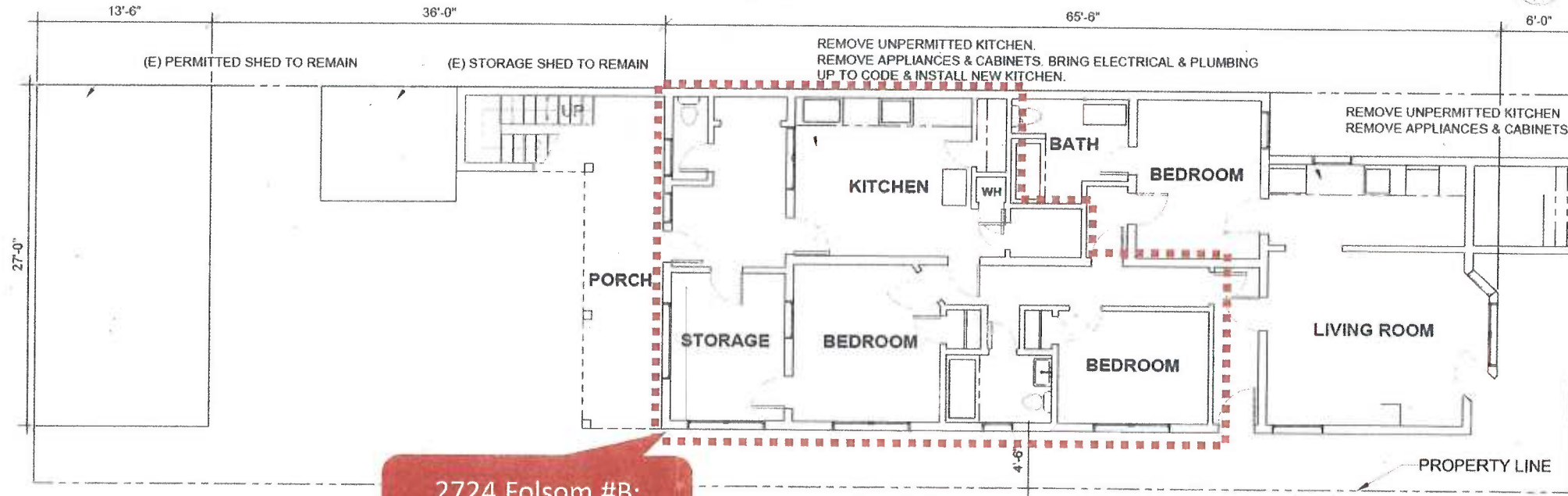

EXISTING GROUND FLOOR PLAN
1/4" = 1'-0"

2724 Folsom #B:
"Back Ground Unit"

Drawing Index:

- A1 Site Plan
- A2 Existing Floor Plans
- A3 Existing Floor Plans
- A4 Proposed Floor Plans
- A5 Proposed Floor Plans

<p>David Locicero architect</p> <p>California Registration C19452</p>	<p>2340 Powell Street, No. 290 Emeryville, CA 94608</p> <p>415.342.2204 dslocicero@gmail.com www.dslociceroarchitect.com</p>	<p>2722 - 2724 Folsom Street 3- UNIT TO 2- UNIT CONVERSION</p>	<p>Michael Turon 2722 - 2724 Folsom Street San Francisco, CA 94110</p> <p>turon@cantab.net</p>	<p>Stamp</p>	<table border="1" style="width: 100%; border-collapse: collapse;"> <thead> <tr> <th>Rev.</th> <th>Date</th> <th>Comments</th> </tr> </thead> <tbody> <tr><td> </td><td> </td><td> </td></tr> <tr><td> </td><td> </td><td> </td></tr> <tr><td> </td><td> </td><td> </td></tr> <tr><td> </td><td> </td><td> </td></tr> <tr><td> </td><td> </td><td> </td></tr> </tbody> </table>	Rev.	Date	Comments																<p>Date: 7/13/2017 Scale: As Shown Drawn By: DSLocicero Checked By: DSLocicero Job Number: 1705</p>	<p>SHEET TITLE</p> <h2 style="font-size: 2em;">A-2</h2>
Rev.	Date	Comments																							

Exhibit C

Subject: 2722 -2724 Folsom St. Letter.

Date: Friday, April 30, 2021 at 7:26:28 PM Pacific Daylight Time

From: Duffy, Joseph (DBI)

To: ryan@zfplaw.com

CC: Sanchez, Scott (CPC)

Hi Ryan.

I hope that you are keeping well. I am contacting you regarding a letter written by you that I was copied on dated April 16th 2021 .The letter is in regards to a suspension request from the SF Planning Department at 2722-2724 Folsom St. In the letter you reference a building permit 202003066357 and particularly some actions that were taken by me when I reviewed the building permit with the owner Mr. Turon at the DBI counter at 1660 Mission St 3rd floor on March 6th 2020.

Mr. Turon was obtaining a no plans building permit for fire damage repair and install new sheetrock in NE Corner only .At the time I was processing the permit on behalf of BID due to an active complaint on the property. I asked Mr. Turon in what area he was doing the work and he said it was in the laundry area. I did not question his answer however I did write it onto the permit based on his reply to my question "All work in Laundry Area only" It is not uncommon for me to ask a customer which area of a building the work is taking place. That information is helpful to our field building inspectors. In your letter you state that this building permit authorized and changed the designation of the room to laundry.

I think you know that as a Senior Building Inspector at DBI Inspection division I do not have the authority to approve changes to room designations .That process would involve filing a building permit with plans and the permit documents would be subject to review by SF Planning and DBI and perhaps other city agencies.

The application that you reference was a no plans permit and just because I was helping a customer fill out some relevant information that he had omitted from the description of work would not mean that I was authorizing the use of the room as a laundry area. If that was the case I would imagine a lot of customer would be lining up to see me. I took Mr. Turon's word for it and a lot of times that is how a permit is issued based on the information supplied by the applicant.

The "abatement "permit 202003066357 did not authorize the space to be designated as a laundry area. I hope that you resolve the issues on the property with the Planning department and I have been in contact with Mr. Turon as he had a question about work that he wanted to continue with on permits that were not suspended.

Thank you and take care.

Joe

Joseph Duffy
Acting Chief Building Inspector
Building Inspection Division
Dept of Building Inspection
San Francisco
628-652-3610

PUBLIC COMMENT

From: [Tammie Presser](#)
To: [BoardofAppeals \(PAB\)](#)
Cc: tpresser@gmail.com
Subject: 2722-2724 Folsom St.
Date: Wednesday, June 2, 2021 12:48:51 PM

This message is from outside the City email system. Do not open links or attachments from untrusted sources.

Dear Board of Appeals,

I have owned and occupied my home in the Mission district of San Francisco since 2009, and have resided in the Mission district since 2001.

I am submitting this letter of support for the Appellant in Case No. 21-035.

I have known members of the Appellant's family for over seven years, and attended their wedding at Foreign Cinema.

Michael and Lauren Turon are upstanding members of the Mission Community, and staunch supporters of our neighborhood.

I am very familiar with the hurdles they have encountered with their property; I previously wrote a letter to the Board regarding their property back in Oct. 2018 (See Case No. 18-093).

It appears that the Planning Department has erred in its suspension request based on the building permit history and the documents recorded on the property. Given these supporting public records, it is also clear that the Appellant in no way "misrepresented" the plans associated with the permits under the suspension request.

The Appellant has engaged in the fire repairs in good faith and under the approval of the city. The Appellant has invested a significant amount of time (7 months) and money (\$400,000+) in making these repairs under the City's approval. They are entitled to complete the work.

Please reinstate the permits and allow for the Appellant's family to finish the repairs to their family home.

Respectfully,

Tammie Presser
2208 Mission St. No. 407
San Francisco, CA 94110

To whom it may concern:

My name is Saul Anaya and I have been a resident of San Francisco and lived on Folsom street since 1964. I have known Michael since he purchased his home back in 2007. I have become closer with him and his family since the pandemic started. Michael and Lauren are very good neighbors who contribute to the beauty and safety of our block and the community.

I was exceptionally sad to hear from Michael and Lauren that they had to pause the repairs on their home this past April. I have seen how much time and effort they have been putting into their repairs during the COVID-19 pandemic. I was surprised to hear that the City asked that the repair work be paused because it believes a room was mislabeled in the permit plans.

Michael shared with me his submission to you. He also shared the completed March 2020 permit where the disputed mislabeled room is labeled as a “Laundry” room.

It looks like that the room is correctly labeled (as “Laundry”) and the City’s own records support this fact.

I hope you all see this as well and allow Michael and Lauren to resume repairs on their home. I would hate to lose them as neighbors and it would be a great loss to the community as a whole because they are unable to complete their repairs.

Best,

Saul Anaya
2712 Folsom St.
San Francisco, CA 94110

From: [Janice Tam](#)
To: [BoardofAppeals \(PAB\)](#)
Subject: Support Letter for Appellant in Case No. 21-035
Date: Wednesday, June 2, 2021 6:31:18 PM

This message is from outside the City email system. Do not open links or attachments from untrusted sources.

Dear Board of Appeals,

I have been living in San Francisco as a renter in the Mission district for 9 years. I befriended Michael and Lauren shortly after they were displaced by a fire destroyed their home.

I have reviewed the brief and the facts Michael submitted earlier to you. Upon my review, it is clear that the Planning Department erred and overlooked several key public documents when it made submitted the Suspension Request; rendering their concerns around inconsistent labels moot.

The evidence submitted also show that Michael and Lauren submitted their permits in good-faith and based on the legal history of the property.

Please rescind the Planning Departments Suspension Request and allow the Appellant to complete repairs to the property.

Respectfully,

Janice Tam, Esq.

From: [Niko Klein](#)
To: [BoardofAppeals \(PAB\)](#)
Subject: Case No 21-035 (2722-2724 Folsom St)
Date: Wednesday, June 2, 2021 9:40:47 PM

This message is from outside the City email system. Do not open links or attachments from untrusted sources.

To Whom It May Concern:

I have come to know Michael Turon as a neighbor of a property I own and as a professional I've had the pleasure of working with. I am acquainted with the incredibly frustrating situation he's working to resolve with the city and am writing to voice my concern and opinion as an owner of a neighboring property.

Please rescind the Planning Department's erroneously issued Suspension Request regarding Case No 21-035 at 2722-2724 Folsom St. To my knowledge, there is no supporting evidence to the concerns raised by the Planning Department in this action. No CCSF department should have the right to stop work on properly reviewed and issued permits outside of the authority clearly established in its rules and regulations. It strikes me as only fair to allow Michael and his wife to continue work on their property under the permits already issued by CCSF.

Kindly,

Nicholas (Niko) Klein
Owner of 2519 Harrison St

From: [Ross Cohen](#)
To: [BoardofAppeals \(PAB\)](#)
Subject: Letter of Support for Case No. 21-035
Date: Wednesday, June 2, 2021 10:34:25 PM

This message is from outside the City email system. Do not open links or attachments from untrusted sources.

Board of Appeals,

I am a resident of San Francisco, who has been living in the City for 20 years with my family.

I have personally known the Appellant and his family for nearly two decades.

The continuous hurdles the City is throwing in front of Michael and his family to repair their fire

damaged home is crazy, especially in light a a few of the following:

- * **Housing Crises:** In the midst of a housing crisis, the City is delaying viable units from returning to the housing stock.
- * **Poor Resource Management:** Numerous hours of CCSF employees' time has been wasted on this one property; even after an agreement has been struck with the City Attorney's office.
- * **Public Record:** The public record shows that the Planning Department erred in its suspension request, yet more resources are getting poured into this hearing.
- * **Vested Rights:** The Appellant has performed a significant amount of work under the CCSF approved permits (which includes Planning approval); the permits are vested and Appellant has a legal right to complete the work.

I ask that the Members of the Board vote to rescind the suspension request, and allow the Appellant to complete the repairs to their family home.

Best,
Ross Cohen
2128 Hayes St.

From: [Sian Townsend](#)
To: [BoardofAppeals \(PAB\)](#)
Subject: Case No. 21-035
Date: Thursday, June 3, 2021 6:28:42 AM

This message is from outside the City email system. Do not open links or attachments from untrusted sources.

Dear Board of Appeals,

This is a letter of support for the Appellant in Case No. 21-035.

I have known Michael (“Appellant”) and his family for several years; they were our neighbors for nearly two years after the fire occurred at their home in 2018.

I am familiar with the appellant’s continuous efforts, over the last three years, of working with the City to correct the building records in order to start repairs on their fire damaged home. I was excited to hear that the appellant had finally received a permit to repair the fire damage in early September, 2020.

I was saddened to hear that the Planning Department requested a suspension of the appellant’s fire repair permit – seven months after construction had started. Michael and his family have invested a lot of time and money in the construction based on the City approved permits.

After reviewing the appellant’s brief, it has become clear to me that the Planning Department erred in its request; the Planning Department’s suspension request is incorrectly based on unissued plans that were submitted nearly 3 years ago (July 2018). The department’s claim is based on inaccurate and outdated plans; the plans that were submitted and approved by the City are accurate and reflect the existing conditions.

This suspension request was done in error - the appellant’s permit plans are accurate and fully supported by the past completed permits.

I am writing this letter to ask that the Board rescind the erroneous suspension request (based on the legal permit history) and re-instate the permits to allow Michael and his family to repair their home.

Best,

Sian Townsend
827 Peru St.
San Francisco, CA 94112

From: [Katie Bailey](#)
To: [BoardofAppeals \(PAB\)](#)
Subject: Case No. 21-035 | Appellate Support
Date: Thursday, June 3, 2021 8:03:34 AM

This message is from outside the City email system. Do not open links or attachments from untrusted sources.

Members of the Board:

I have been living in the Mission as a renter for 3 years. When I moved here, Michael and Lauren helped secure my apartment by meeting my landlord and doing a walkthrough on my behalf. They are more than just kind and helpful people--they are assets to the Mission community.

When I heard that their construction was put on pause, I was devastated. I have been watching the amount of time and care they have been putting into repairing their home during COVID-19 and beyond.

Based on my review of the materials, it appears that the reason for the Suspension Request has been addressed. I am writing to ask that the Board lift the suspension and allow Michael and Lauren to complete their repairs.

Best,
Katie Bailey

MATT COELHO ENGINEERING

2443 Fillmore St #380-6963 · San Francisco, CA 94115

tel: 732.331.5368

matt.coelho@gmail.com

June 3, 2021

Board of Appeals
San Francisco Planning Department
49 South Van Ness Ave, Suite 1400
San Francisco, CA 94103

Subject: Permit Suspension
2722-2724 Folsom St
San Francisco, CA 94110

Members of the Board of Appeals:

I have been working in San Francisco as a licensed professional engineer since 2010; I am very familiar with the complexity of the permit process in San Francisco. I do not believe the plans associated with the Fire Repair and Seismic Retrofit permits of this property have been mislabeled nor misrepresented.

The existing area labeled as "Laundry" in the above-mentioned plans was given its existing designation after work was completed and finalized by DBI under Permit No. 2020-0306-6357.

The former unpermitted kitchen was destroyed in a fire. Its destruction by the fire is documented in DBI's records, both in the recently recorded NSR (Doc. No. K897774) on the property and in the Fire NOV (No. 201842471); the NOV actually explicitly directs the Appellant to "Obtain Building Permit to Perform Fire Damage Repairs. Do not occupy kitchen".

The decision to suspend the permits was based on a set of superseded plans and does not account for more recently issued, and completed, permits; rendering the basis of the Suspension Request moot.

The approved permit plans as submitted are correctly labeled and based on the exhaustively documented legal permit history of the building. Furthermore, the Appellant has completed, in good faith, a significant amount of work on the approved permits, and under the authority of CCSF.

The Appellant has invested considerable time and investment through the years disentangling the use and permit history of this building and I see no reason how this permit suspension benefits the public good. Please remove the permit suspensions and allow the Appellant to complete the repairs.

Sincerely,



Matthew Coelho, P.E., LEED® AP
(C 72747)

From: [Justin Godar](#)
To: [BoardofAppeals \(PAB\)](#)
Subject: Letter of Support for Michael Turon
Date: Thursday, June 3, 2021 9:32:30 AM

This message is from outside the City email system. Do not open links or attachments from untrusted sources.

Dear Board of Appeals,

I wrote to you previously supporting the Appellant on October 3, 2018 (Ref. Case No. 18-093). I am writing to you again to support Michael.

The Suspension Request submitted by the Planning Department has been erroneously issued; the permit history of the property refutes the reasons outlined by the Planning Department in the Suspension Request.

Please lift the Suspension Request and allow Michael and Lauren's to complete repairs on their property.

Sincerely,

Justin Godar

--

Justin Godar
Godar Furniture
2241 Quesada Ave
San Francisco CA 94124
[instagram.com/godarfurniture](https://www.instagram.com/godarfurniture)
godarfurniture.com
415 863 4775

From: [Vas Bailey](#)
To: [BoardofAppeals \(PAB\)](#)
Subject: Letter of Support for M. Turon (Ref. 21-035)
Date: Thursday, June 3, 2021 2:43:50 PM

This message is from outside the City email system. Do not open links or attachments from untrusted sources.

Members of the Board of Appeals,

Over the course of pandemic, I have befriended Michael and Lauren. They have been valuable members of our "COVID pod".

In the course of the last 12 months, I have observed the struggles Michael's family has gone through to repair their home; including the details around the settlement with the City Attorney's office to documenting the destruction of the unpermitted kitchen and the subsequent completed permits labeling it the former areas as "Laundry". I was happy to hear that repairs started at the Appellate's home in September, 2020.

I thought Michael's long journey to repair his family's home was coming to an end in March, and was surprised to learn that the City requested that the work be stopped in April.

I was surprised that the requesting department made no attempt to contact Michael to get clarification on the issued permits, but rather, resorted to a rather extreme action of suspending the permits with zero discussion.

It appears to me that the city erred and did not account for the various public records refuting the City Department's claim of "misrepresentation". Rather, it exposed the diligence Michael went through to follow and document the process.

I hope the Board sees this. I also hope the Board see's the amount of time and money Michael and his family have invested in repair their home based on the Approved permits from the City.

Please remove the erroneous suspension on the Appellee's property and allow his family to complete repairs on their home.

Best,

Vas

From: [Shauna Gallegos](#)
To: [BoardofAppeals \(PAB\)](#)
Subject: Case No. 21-035
Date: Thursday, June 3, 2021 3:14:10 PM

This message is from outside the City email system. Do not open links or attachments from untrusted sources.

Members of the Board:

This letter is in regards to Case No. 21-035.

I met Michael and Lauren Turon several years ago and have been watching their journey to repair their home in San Francisco after a fire caused damage. Recently, I learned that their repairs were abruptly halted after 7 months of construction because the Planning Department believes that the approved permit plans might have some inconsistent in-room labels. The Planning Department's claims appear to be unsubstantiated based on the provided facts and public record.

I find the Planning Department's action in this case puzzling and counterproductive.

Considering the housing shortage in the area, wouldn't it be more beneficial for the City to be working with the property owner to get units repaired and rehabilitated? Shouldn't the City be required to start a dialogue with a property owner and conduct a formal fact-finding mission prior to filing a Suspension Request?

These are the facts of this case: There was a fire at the property. The owner followed the City processes and applied for permits. The permits were reviewed and issued (including by Planning). The owner commenced work to repair their property. Significant work was performed, thus vesting the permits issued by the City. The owner should now have a legal right to complete the work.

I hope the Board reviews the facts in this case, concludes that there were no bad-faith actions surrounding the issuance of the permits, and votes to allow the Appellate to complete their repairs.

The City should not make it so difficult for people to repair their homes after a calamity; they should be working to streamline the process to enable people to move back into their homes.

Respectfully,

Shauna Gallegos

From: [Mathew Nelson](#)
To: [BoardofAppeals \(PAB\)](#)
Subject: Letter of Support for Michael Turon
Date: Thursday, June 3, 2021 4:02:35 PM

This message is from outside the City email system. Do not open links or attachments from untrusted sources.

Dear Board,

I have lived across the street from Michael at 2709 Folsom Street since Michael and his family purchased the property in 2007. I purchased my house in 2002 and feel that Michael and Lauren are excellent neighbors and have been great additions to our community and wish there were more people like them on our street..

I ask that you move to release the suspension on Michael and Lauren's property and allow them to finish their fire repair.

They have been working diligently for the last seven months (during COVID-19) to repair their building after it was damaged in a fire started by a former tenant.

I do not see any evidence that Michael and Lauren submitted faulty (or deceptive) plans to the City; there is no legal justification for the suspension request. In fact, this raises my concerns about if I should improve my property, as I have frequently thought about doing. I have long heard that doing these projects in San Francisco is onerous and driving people out of the city and this seems to be yet another example of this.

Please remove the suspension, and allow them to rebuild their fire damaged property. I am eagerly awaiting this hearing and the decision as it will directly impact my day to day life on Folsom Street.

Thank you,

Mathew Nelson

June 3, 2020

Re: Appeal No. Case No. 21-035 for 2722-2724 Folsom Street

Members of the Board of Appeals,

I have lived in the Mission since 2005. My wife and two children own and live at 2720 Bryant St., a few blocks away Michael and Lauren's home.

Michael and I met through our volunteer efforts at a SF based 501(c)(3) focused on Historical Preservation.

I have reviewed the Michael's brief submission. I ask Members of the Board of the Appeals to vote to approve Appeal No. 21-035 for the following reasons:

- The stated reason to mitigate the Suspension Request is "to allow time for the Permit Holder to address the inconsistencies between the existing conditions shown on the subject permits and prior permits"; specifically, "the area now shown as a laundry room"
- It appears that the Planning Department erred by overlooking a completed building permit, Permit Application No. 2020/0306/6357, which states "All work in Laundry area only" which was inspected and provided a final approval.
- Considering the completed scope of work in Permit Application No. 2020/0306/6357, which establishes the existing conditions expressed in the subject permits of this hearing, the Suspension Request is now moot.

The evidence and CCSF records in this case are convincing, and there do not appear to be inconsistencies in the approved plans that warrant the Suspension Request remain in effect.

I respectfully request that the Suspension Request be lifted and for the approved permitted work to continue.

Sincerely,

Rob Thomson

From: [Doug McDowell](#)
To: [BoardofAppeals \(PAB\)](#)
Subject: Case No 21-035
Date: Friday, June 4, 2021 9:13:04 AM

This message is from outside the City email system. Do not open links or attachments from untrusted sources.

Members of the Board of Appeals,

My name is Doug McDowell and I live at 2774 Folsom St. with my wife and two teenage children. I live a few house down from Michael Turon; we live on the same side of the block.

I wrote to you back in 2018, when Michael and Lauren had started the process of obtaining permits to repair their home; I was actually one of the neighbors who called Michael when the fire started. He was out of town for a wake during President Day weekend.

I have been following Michael's efforts for the last three years and have witnessed, firsthand, the efforts he has gone through with various CCSF Departments to get permits to repair his home.

The recently issued Suspension Request appear to be a superficial.

Upon review, I do not see any errors in the CCSF approved permits. Would you please explain?

I ask that the Members of the Board of Appeals move to release the Suspension Request and allow Michael to complete his repairs. This action is causing hardship for a neighbor and friend.

Sincerely,

Doug McDowell

(415) 610-1620

SF Appeals 21-035

2722-2724 Folsom St., M. Turon owner

Complaint: The front exterior stairs appears to be demolished and rebuilt and are now a significant encroachment onto the sidewalk of Folsom St. They are a severe tripping hazard. This appears to be unpermitted new work. Exceeds explicit scope of #202012211404.

I want to express my adamant support for **DENIAL of the applicants request** to overturn the suspension.

The SF Planning Department has been fair and transparent and yet Mr. Turon believes he is above the law for all residents. Mr. Turon is using the DBI acceptance of specific inspections to 'pretend' that a larger and more inclusive entitlement has been approved. He is trying set-up DBI up against SF Planning and make it look like he is an innocent home owner and not the scoundrel that he is.

Behold the tripping hazard he has placed unto a public sidewalk. He will soon pretend that he has a right to extend his new stairs unto the sidewalk because of irrational belief and that the structure under the stairs was inspected by DBI as 'proof' he was approved to do this.

He doesn't stop. This is the nature of a scoundrel that wastes Board members time, that wastes Planning Staff and DBI time with unsupported claims. For the sake of fairness to all that follow our complicated process please reach the just and natural conclusion to send a message to cheaters.

Per Google street: We observe the lowest tread is few inches beyond the property line previously





This is a brand new staircase and the riser height at the front property line is significantly higher than it was resulting in a new encroachment onto the sidewalk. The newel posts have been reconstructed and raised in spite of prohibition to encroach as per # 202012211404. Mr. Turon doesn't care. He will do as he pleases again.

Description:

Step	Station	Arrive	Start	In Hold	Out Hold	Finish	Checked By	Hold Description
1	INTAKE	12/21/20	12/21/20			12/21/20	PANGELINAN MARIANNE	TO CP-ZOC
2	CP-ZOC	12/29/20	12/29/20			12/29/20	CORRETTE MOSES	Revise to replacement. Re-cast newel posts and replalce trim beneath bull nose of treads
3	BLDG	1/19/21	1/19/21			1/19/21	HUANG VIVIAN	approved. route to BSM
4	DPW- BSM	1/21/21	1/21/21			1/21/21	CHOY CLINTON	Approved. 1/21/21: No alteration or reconstruction of City Right-of-Way under this permit. Routed to Issued Box. -CC
5	CPB	1/25/21	1/25/21			1/25/21	SHAWL HAREGGEWAIN	INV. 1/25/21HS

This permit has been issued. For information pertaining to this permit, please call 688-688-6478.

Now look at this as per June 2021:



Look at the new raised height of the newel posts! The bottom tread is now at about the height of the traffic cone. That means the treads below will have to be extended horizontally onto the sidewalk. He has no right to do this without permission. This was not as it was previously.





Drawing G1.01:

Subject property does not show encroachment of existing stairs into sidewalk

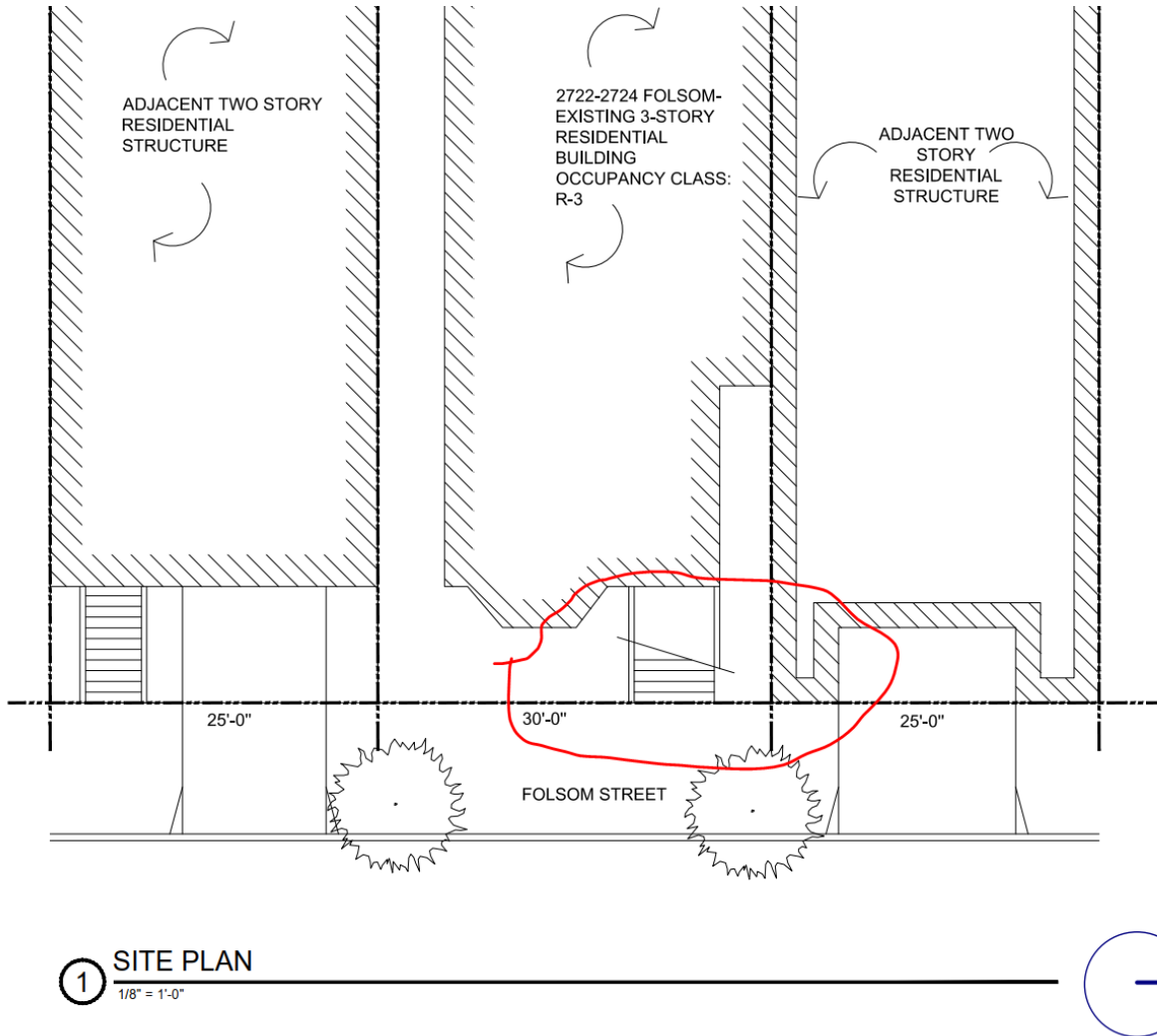

Drawing A2.01

Top image is "Existing" and lower is "Proposed". There is no indication of any work for the front stairs

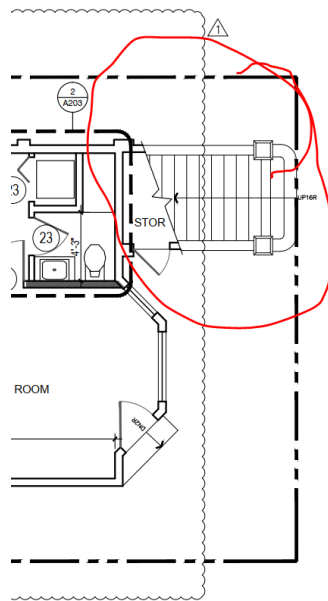
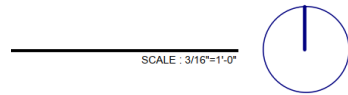
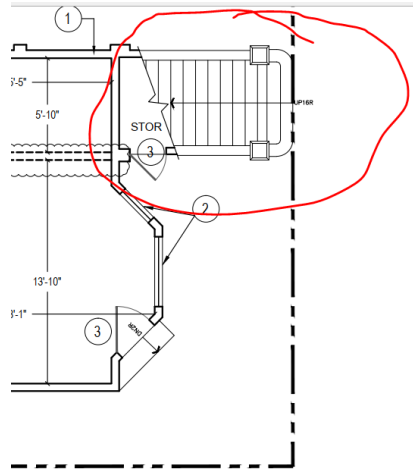

The Structural Plans have no indication of elevation and they indicate no work for the staircase.

Mr. Turon believes he owns the sidewalk of Folsom Street and may build a tripping hazard there without permission because it suits him is just one example of what kind of arrogance he posses in his continued pattern of abusive behavior of the system that he is able to exploit. There is a school one block away. Planning and DBI are doing their jobs to ensure safety of neighbors and visitors. Please DENY his appeal.

----- END of Document-----

From: [Jim Warshell](#)
To: [BoardofAppeals \(PAB\)](#)
Subject: 2722-2724 Folsom Street
Date: Thursday, July 1, 2021 6:24:50 AM

This message is from outside the City email system. Do not open links or attachments from untrusted sources.

Dear Board President Honda, Commissioners Lazarus, Swig and Chang,

I am writing on behalf of Michael and Lauren Turon. I am stating that I believe them to be well intentioned and honorable people. There have been many challenges in getting this property renovated to a safe and updated two unit home. Throughout the challenges, they have remained committed to the goal so that this will be their home in the community where they have built ties and are making important contributions.

They have invested considerable time, effort and financial resources to do this. The house now sits on a secure foundation, has updated mechanical systems and DBI has regularly inspected and confirmed the quality of the work conforming with code. They went to added expense to accurately replace the entry staircase with a historically accurate and beautifully crafted one.

We all know that doing a major project is challenging. This project had its share of additional challenges to overcome. However, these are not short term flippers or developers only concerned with turning as large a profit as possible. These are dedicated and committed people trying hard to make this their long term home. It is in everyone's interest to see this project completed expeditiously. Please help make this happen.

Jim Warshell

Sent from my iPad

From: [Alice Lah](#)
To: [BoardofAppeals \(PAB\)](#)
Subject: Letter of Support for the Turons - Case No. 21-035
Date: Wednesday, June 30, 2021 7:56:31 PM

This message is from outside the City email system. Do not open links or attachments from untrusted sources.

To the SF Board of Appeals,

Based on my time knowing the Turons (Lauren has been a trusted friend of mine for nearly a decade), I can attest that they are an honest and law-abiding family that strives to work within the rules.

I have witnessed Michael and Lauren's journey to repair their home after the 2018 Fire. I have seen the considerable amount of time and effort they spent correcting their building records prior to investing their life's savings into additional life-safety measures to make their home safer for their growing family; including voluntary seismic and fire upgrades.

They also made contributions in beautifying the neighborhood, by hiring a renowned building conservator-restorer to rebuild their front stairs to match the historical fabric of the neighborhood; making them good stewards to the SF housing stock.

As a former resident of San Francisco (I lived in the Mission Dolores neighborhood, District 8), I ask that the Board consider the statements provided in this letter, and seek some sort of compromise in this matter to allow these community members to complete their Fire repairs. Continuing the suspension does no public good. Continuing the suspension drains the City's resources which can be better utilized in other matters, it keeps housing units from re-entering the market, and will displace them from their home.

I ask that you please show compassion and compromise.

Respectfully,
Alice L. Ramsey

June 30, 2021

Appellant Support Letter for Case No. 21-035

To whom it may concern,

My name is Seth Whitaker, and I am San Francisco homeowner and have lived in the mission for over twelve years. I've owned my two-unit building for about three years now; I'm in one unit with my husband, and the other unit is occupied by my disabled mother, who is wheelchair bound and under our care. My sister and her two daughters are also living with my mother while we seek medical treatment for a condition that has rendered her blind.

I have known Michael Turon for over 27 years. We grew up in the east bay and went to high school together. Through the time I have known him, I can attest that he would never misrepresent, lie, or commit fraud to a government body.

The Planning Department is asserting that Michael misrepresented declarations on his permits to the city. Michael told me the circumstances of the fire that destroyed the second kitchen back in 2018. From the documents Michael has shared with me, it appears that the that the Planning Department was aware that the 2nd illegal kitchen was destroyed by fire as far back as October 2018.

It concerns me that the Planning Department granted approval for the Fire Repair Permit on September 2020, and then suspended this permit when the Turons were just one month away from finishing the work on their property. How can the city change the approval at the final hour when these permits and work were completed over the course of three years? I am extremely dismayed that changes in approval status can happen without due cause. Michael has worked very hard to follow the required approval procedures, and I can attest to his honest intention and desire to work within the city's guidelines at every step of the process. I am working with an architect to make my own home more ADA accessible to my family, and so I have watched closely to see how Michael has secured the required approvals from the city, interviewed contractors, and rebuilt the home according to every detail required by code, all with proper approvals garnered.

The Turons made a significant investment in rebuilding their home. They borrowed from their retirement to make their home safer, based on their reliance of the city approved permits. Michael and Lauren should be allowed to complete the approved work and not be punished because the city has retracted the already-granted permits.

I hope this injustice will be alleviated as soon as possible. I have witnessed firsthand that these delays are causing extreme financial and emotional hardship on the Turons. Please lift the suspension and allow Michael and Lauren to complete the repairs to their home.

Respectfully,

Seth Whitaker
374 Bartlett St.

Gail Baugh
700 Hayes Street San Francisco, CA 94102
Gailbaugh40@gmail.com 415-265-0546

July 29, 2021

To: San Francisco Board of Appeals: Commission President Darryl Honda, Commissioners Ann Lazarus, Rick Swig, Tina Chang

From: Gail Baugh
Re: 2722-2724 Folsom St, owners Michael and Lauren Turon

I am writing in support of property owners Michael and Lauren Turon, as they renovate their home. They should be allowed to complete the renovations to their home property. We know Michael and Lauren to be trustworthy and have been trying to resolve all the complexities associated with their property.

They have already contributed to the well-being of their community by helping nearby small businesses apply for COVID-related financial assistance in their neighborhood during the Pandemic. I sincerely believe their intent is to provide a wonderful home for themselves and eventually a tenant.

I urge you to work with them to find an amicable solution to any unresolved issues, so these committed homeowners realize their dream of being part of their community here in San Francisco.

Sincerely, Gail Baugh

From: [Beverly B. Yip](#)
To: [BoardofAppeals \(PAB\)](#)
Cc: [Beverly Yip](#)
Subject: Case #21-035 - Letter of Support for the Turons
Date: Thursday, July 1, 2021 12:30:41 PM

This message is from outside the City email system. Do not open links or attachments from untrusted sources.

Dear Respectable Members of the Board of Appeals,

I live in San Francisco (District 5), which has been my home for the last 24 years. Born and raised in our beautiful city San Francisco, I am proud graduate of San Francisco State University. I have started several businesses here, while serving the Board of Directors for Donaldina Cameron House, a non profit in Chinatown.

Based on my time knowing the Turons, I can attest that they are an honest and law-abiding family that strive to work within the rules. I have witnessed Michael and Lauren's journey to repair their home after the 2018 Fire. I have seen the considerable amount of time and effort they spent correcting their building records prior to investing their life's savings into additional life-safety measures to make their home safer for their growing family; including voluntary seismic and fire upgrades.

It's through our shared struggles to start a family that I met the Turons. They have an excellent support system for my partner and I. I have seen first hand the toll of the stress of the delayed of the fire repairs that has taken on them, adding unnecessary pain to an already difficult situation.

I ask that the Board consider the statements provided in this letter, and seek some sort of compromise in this matter to allow these beloved community members to complete their Fire repairs. Continuing the suspension does no public good. Continuing the suspension drains the City's resources which can be better utilized in other matters, it keeps housing units from re-entering the market, and will displace them from their home.

San Francisco may not be what it once was growing up. Everything has changed for better or for worst, but it's **people** who I've met that has HEART and SOUL, like Michael and Lauren, that makes me proud to (still be) a San Franciscan. I met them in San Francisco, and for that reason, I still have hope for our city that we still have GOOD PEOPLE living here. I am grateful for their friendship and please, I ask you to show compassion and compromise.

Respectfully,

Beverly B. Yip
Business Owner
Member of Donaldina Cameron House, Board of Directors 2012 - 2008
(415) 812-8777

--

Best Regards,
Beverly Yip

From: [Karla Martin](#)
To: [BoardofAppeals \(PAB\)](#)
Subject: Case #21-035 - Letter of Support for the Turons
Date: Thursday, July 1, 2021 2:03:31 PM

This message is from outside the City email system. Do not open links or attachments from untrusted sources.

Dear Members of the Board of Appeals,

I have been a resident of San Francisco for 28 years, currently living on Lake Street in District 2, which has been my home for the last six years.

I have known Lauren Turon for over a decade, first meeting in a professional setting and continuing our relationship well past that. I was so pleased when she met Michael they started their life together in San Francisco.

I can attest the Turons are an honest and law-abiding family that strives to work within the rules. I have witnessed their journey to repair their home after the 2018 Fire. I have seen the considerable amount of time and effort they spent correcting their building records prior to investing their entire life's savings into additional life-safety measures to make their home safer for their growing family; including voluntary seismic and fire upgrades.

As a Black woman, I can say that the Turons are exactly the kind of families I want to see in San Francisco; they are committed to helping to build and support diverse and inclusive neighborhoods and supporting local businesses. They are the farthest thing in the world from some of the recent tech transplants who would see San Francisco become Silicon Valley north and its distinctive character in the process.

I ask that the Board consider the statements provided in this letter, and seek some sort of compromise in this matter to allow these beloved community members to complete their Fire repairs. Continuing the suspension does no public good. Continuing the suspension drains the City's resources which can be better utilized in other matters, it keeps housing units from re-entering the market, and will displace them San Francisco.

I ask that you please show compassion and compromise.

Regards,
Karla Martin